

# TC8300

Touch Computer



**ZEBRA**

## **Product Reference Guide** for Android™ 11

ZEBRA and the stylized Zebra head are trademarks of Zebra Technologies Corporation, registered in many jurisdictions worldwide. Google, Android, Google Play and other marks are trademarks of Google LLC. All other trademarks are the property of their respective owners. ©2021 Zebra Technologies Corporation and/or its affiliates. All rights reserved.

Information in this document is subject to change without notice. The software described in this document is furnished under a license agreement or nondisclosure agreement. The software may be used or copied only in accordance with the terms of those agreements.

For further information regarding legal and proprietary statements, please go to:

SOFTWARE: [zebra.com/linkoslegal](https://zebra.com/linkoslegal).

COPYRIGHTS: [zebra.com/copyright](https://zebra.com/copyright).

WARRANTY: [zebra.com/warranty](https://zebra.com/warranty).

END USER LICENSE AGREEMENT: [zebra.com/eula](https://zebra.com/eula).

## Terms of Use

### Proprietary Statement

This manual contains proprietary information of Zebra Technologies Corporation and its subsidiaries (“Zebra Technologies”). It is intended solely for the information and use of parties operating and maintaining the equipment described herein. Such proprietary information may not be used, reproduced, or disclosed to any other parties for any other purpose without the express, written permission of Zebra Technologies.

### Product Improvements

Continuous improvement of products is a policy of Zebra Technologies. All specifications and designs are subject to change without notice.

### Liability Disclaimer

Zebra Technologies takes steps to ensure that its published Engineering specifications and manuals are correct; however, errors do occur. Zebra Technologies reserves the right to correct any such errors and disclaims liability resulting therefrom.

### Limitation of Liability

In no event shall Zebra Technologies or anyone else involved in the creation, production, or delivery of the accompanying product (including hardware and software) be liable for any damages whatsoever (including, without limitation, consequential damages including loss of business profits, business interruption, or loss of business information) arising out of the use of, the results of use of, or inability to use such product, even if Zebra Technologies has been advised of the possibility of such damages. Some jurisdictions do not allow the exclusion or limitation of incidental or consequential damages, so the above limitation or exclusion may not apply to you.

# Contents

<b>About this Guide.....</b>	<b>13</b>
Configurations.....	13
Notational Conventions.....	20
Icon Conventions.....	20
Service Information.....	21
Determining Software Versions.....	21
Determining the Serial Number.....	21
<b>Getting Started.....</b>	<b>22</b>
Unpacking the Device.....	22
Removing the Screen Protective Film.....	22
Features.....	23
Setting Up the Device.....	25
Installing the microSD Card.....	25
Installing the Battery.....	27
Device Charging.....	28
Powering on the Device.....	29
Google Account Setup.....	30
Installing the Hand Strap.....	30
Hot Swap Mode.....	31
Replacing the Battery.....	32
<b>Using the Device.....</b>	<b>35</b>
Home Screen.....	35
Setting Home Screen Rotation.....	36

Status Bar.....	37
Managing Notifications.....	40
Opening the Quick Access Panel.....	40
Editing Icons on the Quick Settings Bar.....	42
Battery Management.....	43
Checking Battery Status.....	43
Monitoring Battery Usage.....	43
Low Battery Notification.....	43
Turning Off the Radios.....	44
Interactive Sensor Technology.....	44
Waking The Device.....	44
USB Communication.....	45
Transferring Files.....	45
Transferring Photos.....	45
Disconnect from the Host Computer.....	45
<b>Settings.....</b>	<b>47</b>
Accessing Settings.....	47
Display Settings.....	47
Setting the Screen Brightness Manually.....	47
Setting Night Light.....	47
Setting Screen Rotation.....	48
Setting Screen Timeout.....	48
Setting Ambient Display.....	48
Setting Font Size.....	49
Setting Display Size.....	49
Setting Touch Panel Mode.....	49
Setting the Date And Time.....	49
General Sound Setting.....	50
Sound Options.....	50
Setting the Wake Up Sources.....	51
Remapping A Button.....	51
Keyboards.....	51
Keyboard Configuration.....	52

Enabling Keyboards.....	52
Switching Between Keyboards.....	52
Using the Android and Gboard Keyboards.....	52
Edit Text.....	52
Entering Numbers, Symbols, and Special Characters.....	52
Enterprise Keyboard.....	53
Numeric Tab.....	53
Alpha Tab.....	53
Additional Character Tab.....	53
Scan Tab.....	53
Language Usage.....	53
Changing the Language Setting.....	53
Adding Words to the Dictionary.....	54
Notifications.....	54
Setting App Notifications.....	54
Viewing Notifications.....	55
Controlling Lock Screen Notifications.....	56
Enabling Blink Light.....	56
<b>Applications.....</b>	<b>57</b>
Installed Applications.....	57
Accessing Apps.....	58
Switching Between Recent Apps.....	58
Battery Manager.....	59
Opening Battery Manager.....	59
Battery Manager Information.....	59
Camera.....	61
Taking Photos.....	62
Taking a Panoramic Photo.....	63
Recording Videos.....	63
Photo Settings.....	65
Video Settings.....	66
DWDemo.....	67
Datawedge Demonstration Icons.....	67

Selecting a Scanner.....	67
PTT Express Voice Client.....	68
PTT Express User Interface.....	68
PTT Audible Indicators.....	69
PTT Notification Icons.....	69
Enabling PTT Communication.....	70
Selecting a Talk Group.....	70
PTT Communication.....	70
Disabling PTT Communication.....	70
Rxlogger.....	71
RxLogger Configuration.....	71
Configuration File.....	71
Enabling Logging.....	71
Disabling Logging.....	71
Extracting Log Files.....	71
Backing Up Data.....	71
RxLogger Utility.....	72
<b>Data Capture.....</b>	<b>73</b>
Status LED.....	74
Laser Scanning.....	74
Imaging.....	74
Operational Modes.....	74
Digital Camera.....	75
Scanning Considerations.....	75
Scanning with the Camera.....	75
Scanning with the Internal Laser Scanner.....	76
Scanning with the Internal Imager.....	77
Scanning with the RS5100 Ring Scanner.....	81
Scanning with the RS6000 Bluetooth Ring Scanner.....	82
Scanning with the DS2278 Digital Scanner.....	85
Scanning with the DS3678 Bluetooth Scanner.....	86
Scanning with the LI3678 Linear Imager.....	88
Scanning with the DS8178 Digital Scanner.....	89

Pairing a Bluetooth Scanner.....	90
Pairing Using Simple Serial Interface.....	90
Pairing Using Bluetooth Human Interface Device.....	91
Hands Free Scanning.....	92
Hands Free Scanning Settings.....	94
Scanning Mode.....	96
Proximity Range.....	96
DataWedge.....	97
Enabling DataWedge.....	97
Disabling DataWedge.....	97
Supported Devices.....	98
Camera Supported Decoders.....	98
SE965 Internal Laser Scanner Supported Decoders.....	98
SE4850-ER, SE4770-SR, SE4750-MR Internal Imager Supported Decoders.....	99
SE4750-DP and SE4750-DPA Internal Imager Supported Decoders.....	100
RS5100 Supported Decoders.....	101
RS6000 Supported Decoders.....	102
DS2278 Supported Decoders.....	102
DS3678 Supported Decoders.....	103
LI3678 Supported Decoders.....	104
DS8178 Supported Decoders.....	105
<b>Wireless.....</b>	<b>106</b>
Wireless Local Area Networks.....	106
Connecting to a Wi-Fi Network.....	107
Removing a Wi-Fi Network.....	107
WLAN Configuration.....	108
Configuring a Secure Wi-Fi Network.....	108
Manually Adding a Wi-Fi Network.....	109
Configuring for a Proxy Server.....	110
Configuring the Device to Use a Static IP Address.....	110
Wi-Fi Preferences.....	111
Additional Wi-Fi Settings.....	111
Wi-Fi Direct.....	112

Bluetooth.....	112
Adaptive Frequency Hopping.....	112
Security.....	113
Bluetooth Profiles.....	113
Bluetooth Power States.....	115
Bluetooth Radio Power.....	115
Discovering Bluetooth Device(s).....	115
Changing the Bluetooth Name.....	116
Connecting to a Bluetooth Device.....	116
Selecting Profiles on the Bluetooth Device.....	116
Unpairing a Bluetooth Device.....	116
Cast.....	116
Near Field Communications.....	117
Reading NFC Cards.....	118
Enterprise NFC Settings.....	118
<b>Accessories.....</b>	<b>120</b>
Device Accessories.....	120
Battery Charging.....	122
Main Battery Charging.....	122
Spare Battery Charging.....	123
Charging the Device.....	123
Charging the Spare Battery.....	123
Charging Temperature.....	124
2-Slot USB Charge Cradle.....	124
Setup.....	126
5-Slot Charge Only Cradle.....	127
Setup.....	128
5-Slot Charge Only Cradle with Battery Charger.....	128
Setup.....	129
5-Slot Ethernet Cradle.....	130
Setup.....	130
Daisy-chaining Ethernet Cradles.....	131
Ethernet Settings.....	132



Configuring for a Proxy Server.....	132
Configuring Ethernet Static IP Address.....	133
LED Indicators.....	133
Establishing Ethernet Connection.....	134
5-Slot Ethernet Cradle with Battery Charger.....	134
Setup.....	135
Daisy-chaining Ethernet Cradles.....	135
Ethernet Settings.....	135
Establishing Ethernet Connection.....	136
4-Slot Battery Charger.....	136
Four Slot Battery Charger Setup.....	137
Battery Charging.....	137
2-Slot Desk Bracket.....	138
2-Slot Desk Mount Assembly.....	138
Mounting Cradle.....	139
5-Slot Desktop Bracket.....	140
5-Slot Desk Mount Assembly.....	140
Mounting Cradle.....	141
Cart Mount.....	142
Installing Cart Mount.....	143
Installing 5-Slot Cradle Rack.....	144
Installing 4-Slot Battery Chargers Rack.....	147
Installing Rack Mount.....	150
Installing 5-Slot Cradle Wall.....	153
Bottom Tray Assembly.....	153
Bracket Wall Mounting.....	153
4-Slot Battery Charger Wall Installation.....	155
Bottom Tray Assembly.....	156
Bracket Wall Mounting.....	156
Condensation Resistant Rear Bezel Replacement.....	157
<b>Application Deployment.....</b>	<b>160</b>
Android Security.....	160
Installing a Secure Certificate.....	160

Configuring Credential Storage Settings.....	161
Android Development Tools.....	161
Android Development Workstation.....	161
Enabling Developer Options.....	161
EMDK for Android.....	162
StageNow for Android.....	162
GMS Restricted.....	162
ADB USB Setup.....	163
Enabling USB Debugging.....	163
Entering Android Recovery Manually.....	164
Application Installation Methods.....	164
Installing Applications Using the USB Connection.....	164
Installing Applications Using the Android Debug Bridge.....	165
Installing Applications Using Wireless ADB.....	165
Installing Applications Using a microSD Card.....	167
Uninstalling an Application.....	167
Android System Update.....	168
Performing a System Update Using microSD Card.....	168
Performing a System Update Using ADB.....	168
Performing a System Update Using Wireless ADB.....	169
Verifying System Update Installation.....	171
Android Enterprise Reset.....	171
Performing an Enterprise Reset From Device Settings.....	171
Performing an Enterprise Reset Using microSD Card.....	172
Performing an Enterprise Reset Using ADB.....	172
Performing an Enterprise Reset Using Wireless ADB.....	173
Android Factory Reset.....	175
Performing a Factory Reset Using microSD Card.....	175
Performing a Factory Reset Using ADB.....	176
Performing a Factory Rest Using Wireless ADB.....	177
Android Storage.....	178
Random Access Memory.....	179
Internal Storage.....	179
External Storage.....	179

Enterprise Folder.....	180
Managing Apps.....	180
App Details.....	181
Managing Downloads.....	181
<b>Maintenance and Troubleshooting.....</b>	<b>182</b>
Maintaining the Device.....	182
Battery Safety Guidelines.....	182
Cleaning Instructions.....	183
Approved Cleanser Active Ingredients.....	183
Harmful Ingredients.....	184
Device Cleaning Instructions.....	184
Special Cleaning Notes.....	184
Cleaning Materials Required.....	184
Cleaning Frequency.....	184
Cleaning the Device.....	185
Housing.....	185
Display.....	185
Exit Window.....	185
Cleaning Battery Connectors.....	185
Cleaning Cradle Connectors.....	185
Troubleshooting.....	186
Resetting the Device.....	186
Troubleshooting the Device.....	186
<b>Specifications.....</b>	<b>189</b>
Data Capture Supported Symbologies.....	189
SE965 Standard Range Laser Decode Zones.....	189
SE4750-MR Decode Zones.....	190
SE4750-DP Decode Zones.....	191
SE4750-DPW Decode Zones.....	192
SE4770-SR Decode Zones.....	193
SE4850 Decode Zones.....	193

I/O Connector Pin-Outs.....	195
2-Slot USB Charge Cradle Technical Specifications.....	195
2-Slot DPM USB Charge Cradle Technical Specifications.....	196
5-Slot Charge Only Cradle Technical Specifications.....	197
5-Slot Charge Only Cradle with Battery Charger Technical Specifications.....	197
5-Slot Ethernet Cradle Technical Specifications.....	198
5-Slot Ethernet Cradle with Battery Charger Technical Specifications.....	198
4-Slot Battery Charger Technical Specifications.....	199
USB and Charging Cable Technical Specifications.....	199
Quick Disconnect Audio Cable Technical Specifications.....	200
3.5 mm Audio Cable Technical Specifications.....	200

# About this Guide

This guide provides information about using the TC8300 touch computer. Screens and windows pictured in this guide are samples and can differ from actual screens.

## Configurations

The TC8300 includes standard, condensation resistant, and premium configurations.

**Table 1** Configurations

Configuration	Radios	Data Capture	Camera	Display	Memory	Operating System
<b>Base</b>						
TC83B0-A005A510NA	802.11 a/b/g/n/ac Bluetooth 5.0	SE965 Laser Engine	No	4" WVGA Color	4G RAM/ 32 GB Flash	Android- based, Google™ Moblie Services (GMS) 11
TC83B0-2005A510NA	802.11 a/b/g/n/ac Bluetooth 5.0	SE4750-MR Imager	No	4" WVGA Color	4G RAM/ 32 GB Flash	Android- based, Google™ Moblie Services (GMS) 11
TC83B0-3005A510NA	802.11 a/b/g/n/ac Bluetooth 5.0	SE4850 Imager	No	4" WVGA Color	4G RAM/ 32 GB Flash	Android- based, Google™ Moblie Services (GMS) 11
TC83B0-6005A510NA	802.11 a/b/g/n/ac Bluetooth 5.0	SE4770-SR Imager	No	4" WVGA Color	4G RAM/ 32 GB Flash	Android- based, Google™ Moblie Services (GMS) 11

**Table 1** Configurations (Continued)

Configuration	Radios	Data Capture	Camera	Display	Memory	Operating System
TC83B0-A005A510RW	802.11 a/b/g/n/ac Bluetooth 5.0	SE965 Laser Engine	No	4" WVGA Color	4G RAM/ 32 GB Flash	Android- based, Google™ Moblie Services (GMS) 11
TC83B0-2005A510RW	802.11 a/b/g/n/ac Bluetooth 5.0	SE4750-MR Imager	No	4" WVGA Color	4G RAM/ 32 GB Flash	Android- based, Google™ Moblie Services (GMS) 11
TC83B0-3005A510RW	802.11 a/b/g/n/ac Bluetooth 5.0	SE4850 Imager	No	4" WVGA Color	4G RAM/ 32 GB Flash	Android- based, Google™ Moblie Services (GMS) 11
TC83B0-6005A510RW	802.11 a/b/g/n/ac Bluetooth 5.0	SE4770-SR Imager	No	4" WVGA Color	4G RAM/ 32 GB Flash	Android- based, Google™ Moblie Services (GMS) 11
TC83B0-2005A510CN	802.11 a/b/g/n/ac Bluetooth 5.0	SE4750-MR Imager	No	4" WVGA Color	4G RAM/ 32 GB Flash	Android- based, Google™ Moblie Services (GMS) 11
TC83B0-3005A510CN	802.11 a/b/g/n/ac Bluetooth 5.0	SE4850 Imager	No	4" WVGA Color	4G RAM/ 32 GB Flash	Android- based, Google™ Moblie Services (GMS) 11
TC83B0-6005A510CN	802.11 a/b/g/n/ac Bluetooth 5.0	SE4770-SR Imager	No	4" WVGA Color	4G RAM/ 32 GB Flash	Android- based, Google™ Moblie Services (GMS) 11
TC83B0-2005A510IN	802.11 a/b/g/n/ac Bluetooth 5.0	SE4750-MR Imager	No	4" WVGA Color	4G RAM/ 32 GB Flash	Android- based, Google™ Moblie Services (GMS) 11

**Table 1** Configurations (Continued)

Configuration	Radios	Data Capture	Camera	Display	Memory	Operating System
TC83B0-3005A510IN	802.11 a/b/g/n/ac Bluetooth 5.0	SE4850 Imager	No	4" WVGA Color	4G RAM/ 32 GB Flash	Android- based, Google™ Moblie Services (GMS) 11
TC83B0-6005A510IN	802.11 a/b/g/n/ac Bluetooth 5.0	SE4770-SR Imager	No	4" WVGA Color	4G RAM/ 32 GB Flash	Android- based, Google™ Moblie Services (GMS) 11
<b>Condensation Resistant</b>						
TC83B0-2005A61CNA	802.11 a/b/g/n/ac Bluetooth 5.0	SE4750-MR Imager	No	4" WVGA Color	4G RAM/ 32 GB Flash	Android- based, Google™ Moblie Services (GMS) 11
TC83B0-3005A61CNA	802.11 a/b/g/n/ac Bluetooth 5.0	SE4850 Imager	No	4" WVGA Color	4G RAM/ 32 GB Flash	Android- based, Google™ Moblie Services (GMS) 11
TC83B0-6005A61CNA	802.11 a/b/g/n/ac Bluetooth 5.0	SE4770-SR Imager	No	4" WVGA Color	4G RAM/ 32 GB Flash	Android- based, Google™ Moblie Services (GMS) 11
TC83B0-2005A61CRW	802.11 a/b/g/n/ac Bluetooth 5.0	SE4750-MR Imager	No	4" WVGA Color	4G RAM/ 32 GB Flash	Android- based, Google™ Moblie Services (GMS) 11
TC83B0-3005A61CRW	802.11 a/b/g/n/ac Bluetooth 5.0	SE4850 Imager	No	4" WVGA Color	4G RAM/ 32 GB Flash	Android- based, Google™ Moblie Services (GMS) 11
TC83B0-6005A61CRW	802.11 a/b/g/n/ac Bluetooth 5.0	SE4770-SR Imager	No	4" WVGA Color	4G RAM/ 32 GB Flash	Android- based, Google™ Moblie Services (GMS) 11

**Table 1** Configurations (Continued)

Configuration	Radios	Data Capture	Camera	Display	Memory	Operating System
TC83B0-2005A61CCN	802.11 a/b/g/n/ac Bluetooth 5.0	SE4750-MR Imager	No	4" WVGA Color	4G RAM/ 32 GB Flash	Android- based, Google™ Moblie Services (GMS) 11
TC83B0-3005A61CCN	802.11 a/b/g/n/ac Bluetooth 5.0	SE4850 Imager	No	4" WVGA Color	4G RAM/ 32 GB Flash	Android- based, Google™ Moblie Services (GMS) 11
TC83B0-2005A61CIN	802.11 a/b/g/n/ac Bluetooth 5.0	SE4750-MR Imager	No	4" WVGA Color	4G RAM/ 32 GB Flash	Android- based, Google™ Moblie Services (GMS) 11
TC83B0-3005A61CIN	802.11 a/b/g/n/ac Bluetooth 5.0	SE4850 Imager	No	4" WVGA Color	4G RAM/ 32 GB Flash	Android- based, Google™ Moblie Services (GMS) 11
<b>Package 1</b>						
TC83BH-2205A710NA	802.11 a/b/g/n/ac Bluetooth 5.0 NFC	SE4750-MR Imager	Yes	4" WVGA Color	4G RAM/ 32 GB Flash	Android- based, Google™ Moblie Services (GMS) 11
TC83BH-3205A710NA	802.11 a/b/g/n/ac Bluetooth 5.0 NFC	SE4850 Imager	Yes	4" WVGA Color	4G RAM/ 32 GB Flash	Android- based, Google™ Moblie Services (GMS) 11
TC83BH-6205A710NA	802.11 a/b/g/n/ac Bluetooth 5.0 NFC	SE4770-SR Imager	Yes	4" WVGA Color	4G RAM/ 32 GB Flash	Android- based, Google™ Moblie Services (GMS) 11
TC83BH-2205A710RW	802.11 a/b/g/n/ac Bluetooth 5.0 NFC	SE4750-MR Imager	Yes	4" WVGA Color	4G RAM/ 32 GB Flash	Android- based, Google™ Moblie Services (GMS) 11



**Table 1** Configurations (Continued)

Configuration	Radios	Data Capture	Camera	Display	Memory	Operating System
TC83BH-3205A710RW	802.11 a/b/g/n/ac Bluetooth 5.0 NFC	SE4850 Imager	Yes	4" WVGA Color	4G RAM/ 32 GB Flash	Android- based, Google™ Moblie Services (GMS) 11
TC83BH-6205A710RW	802.11 a/b/g/n/ac Bluetooth 5.0 NFC	SE4770-SR Imager	Yes	4" WVGA Color	4G RAM/ 32 GB Flash	Android- based, Google™ Moblie Services (GMS) 11
TC83BH-2205A710CN	802.11 a/b/g/n/ac Bluetooth 5.0 NFC	SE4750-MR Imager	Yes	4" WVGA Color	4G RAM/ 32 GB Flash	Android- based, Google™ Moblie Services (GMS) 11
TC83BH-3205A710CN	802.11 a/b/g/n/ac Bluetooth 5.0 NFC	SE4850 Imager	Yes	4" WVGA Color	4G RAM/ 32 GB Flash	Android- based, Google™ Moblie Services (GMS) 11
TC83BH-2205A710IN	802.11 a/b/g/n/ac Bluetooth 5.0 NFC	SE4750-MR Imager	Yes	4" WVGA Color	4G RAM/ 32 GB Flash	Android- based, Google™ Moblie Services (GMS) 11
TC83BH-3205A710IN	802.11 a/b/g/n/ac Bluetooth 5.0 NFC	SE4850 Imager	Yes	4" WVGA Color	4G RAM/ 32 GB Flash	Android- based, Google™ Moblie Services (GMS) 11
<b>Package 2 High Memory</b>						
TC83BH-2206A710NA	802.11 a/b/g/n/ac Bluetooth 5.0 NFC	SE4750-MR Imager	Yes	4" WVGA Color	8G RAM/ 128 GB Flash	Android- based, Google™ Moblie Services (GMS) 11
TC83BH-3206A710NA	802.11 a/b/g/n/ac Bluetooth 5.0 NFC	SE4850 Imager	Yes	4" WVGA Color	8G RAM/ 128 GB Flash	Android- based, Google™ Moblie Services (GMS) 11

**Table 1** Configurations (Continued)

Configuration	Radios	Data Capture	Camera	Display	Memory	Operating System
TC83BH-6206A710NA	802.11 a/b/g/n/ac Bluetooth 5.0 NFC	SE4770-SR Imager	Yes	4" WVGA Color	8G RAM/ 128 GB Flash	Android- based, Google™ Moblie Services (GMS) 11
TC83BH-6206A710RW	802.11 a/b/g/n/ac Bluetooth 5.0 NFC	SE4770-SR Imager	Yes	4" WVGA Color	8G RAM/ 128 GB Flash	Android- based, Google™ Moblie Services (GMS) 11
TC83BH-2206A710RW	802.11 a/b/g/n/ac Bluetooth 5.0 NFC	SE4750-MR Imager	Yes	4" WVGA Color	8G RAM/ 128 GB Flash	Android- based, Google™ Moblie Services (GMS) 11
TC83BH-3206A710RW	802.11 a/b/g/n/ac Bluetooth 5.0 NFC	SE4850 Imager	Yes	4" WVGA Color	8G RAM/ 128 GB Flash	Android- based, Google™ Moblie Services (GMS) 11
<b>Direct Part Mark (DPM)</b>						
TC83B0-4005A610NA	802.11 a/b/g/n/ac Bluetooth 5.0	SE4750-DP Imager	No	4" WVGA Color	4G RAM/ 32 GB Flash	Android- based, Google™ Moblie Services (GMS) 11
TC83B0-4005A610RW	802.11 a/b/g/n/ac Bluetooth 5.0	SE4750-DP Imager	No	4" WVGA Color	4G RAM/ 32 GB Flash	Android- based, Google™ Moblie Services (GMS) 11
TC83B0-4005A610CN	802.11 a/b/g/n/ac Bluetooth 5.0	SE4750-DP Imager	No	4" WVGA Color	4G RAM/ 32 GB Flash	Android- based, Google™ Moblie Services (GMS) 11
TC83B0-5005A610NA	802.11 a/b/g/n/ac Bluetooth 5.0	SE4750- DPA Imager	No	4" WVGA Color	4G RAM/ 32 GB Flash	Android- based, Google™ Moblie Services (GMS) 11

**Table 1** Configurations (Continued)

Configuration	Radios	Data Capture	Camera	Display	Memory	Operating System
TC83B0-5005A610RW	802.11 a/b/g/n/ac Bluetooth 5.0	SE4750-DPA Imager	No	4" WVGA Color	4G RAM/ 32 GB Flash	Android-based, Google™ Mobile Services (GMS) 11
TC83B0-5005A610CN	802.11 a/b/g/n/ac Bluetooth 5.0	SE4750-DPA Imager	No	4" WVGA Color	4G RAM/ 32 GB Flash	Android-based, Google™ Mobile Services (GMS) 11
TC83B0-4005A610IN	802.11 a/b/g/n/ac Bluetooth 5.0	SE4750-DP Imager	No	4" WVGA Color	4G RAM/ 32 GB Flash	Android-based, Google™ Mobile Services (GMS) 11
TC83B0-5005A610IN	802.11 a/b/g/n/ac Bluetooth 5.0	SE4750-DPA Imager	No	4" WVGA Color	4G RAM/ 32 GB Flash	Android-based, Google™ Mobile Services (GMS) 11
<b>TAA</b>						
TC83B0-2005A510TA	802.11 a/b/g/n/ac Bluetooth 5.0	SE4750-MR Imager	No	4" WVGA Color	4G RAM/ 32 GB Flash	Android-based, Google™ Mobile Services (GMS) 11
TC83B0-3005A510TA	802.11 a/b/g/n/ac Bluetooth 5.0	SE4850 Imager	No	4" WVGA Color	4G RAM/ 32 GB Flash	Android-based, Google™ Mobile Services (GMS) 11
TC83B0-6005A510TA	802.11 a/b/g/n/ac Bluetooth 5.0	SE4770-SR Imager	No	4" WVGA Color	4G RAM/ 32 GB Flash	Android-based, Google™ Mobile Services (GMS) 11
TC83BH-6205A710TA	802.11 a/b/g/n/ac Bluetooth 5.0 NFC	SE4770-SR Imager	Yes	4" WVGA Color	4G RAM/ 32 GB Flash	Android-based, Google™ Mobile Services (GMS) 11

**Table 1** Configurations (Continued)

Configuration	Radios	Data Capture	Camera	Display	Memory	Operating System
TC83BH-2205A710TA	802.11 a/b/g/n/ac Bluetooth 5.0 NFC	SE4750-MR Imager	Yes	4" WVGA Color	4G RAM/ 32 GB Flash	Android- based, Google™ Moblie Services (GMS) 11
TC83BH-3205A710TA	802.11 a/b/g/n/ac Bluetooth 5.0 NFC	SE4850 Imager	Yes	4" WVGA Color	4G RAM/ 32 GB Flash	Android- based, Google™ Moblie Services (GMS) 11

## Notational Conventions

The following conventions are used in this document:

- **Bold** text is used to highlight the following:
  - Dialog box, window, and screen names
  - Drop-down list and list box names
  - Checkbox and radio button names
  - Icons on a screen
  - Key names on a keypad
  - Button names on a screen
- Bullets (•) indicate:
  - Action items
  - List of alternatives
  - Lists of required steps that are not necessarily sequential.
- Sequential lists (for example, those that describe step-by-step procedures) appear as numbered lists.

## Icon Conventions

The documentation set is designed to give the reader more visual clues. The following graphic icons are used throughout the documentation set.



**NOTE:** The text here indicates information that is supplemental for the user to know and that is not required to complete a task. The text here indicates information that is important for the user to know.



**IMPORTANT:** The text here indicates information that is important for the user to know.



**CAUTION:** If the precaution is not heeded, the user could receive a minor or moderate injury.



**WARNING:** If danger is not avoided, the user CAN be seriously injured or killed.



**DANGER:** If danger is not avoided, the user WILL be seriously injured or killed.

## Service Information

If you have a problem with your equipment, contact Zebra Global Customer Support for your region. Contact information is available at: [zebra.com/support](https://zebra.com/support).

When contacting support, please have the following information available:

- Serial number of the unit
- Model number or product name
- Software type and version number

Zebra responds to calls by email, telephone, or fax within the time limits set forth in support agreements.

If your problem cannot be solved by Zebra Customer Support, you may need to return your equipment for servicing and will be given specific directions. Zebra is not responsible for any damages incurred during shipment if the approved shipping container is not used. Shipping the units improperly can possibly void the warranty.

If you purchased your Zebra business product from a Zebra business partner, contact that business partner for support.

## Determining Software Versions

Before contacting Customer Support, determine the current software version on your device.

1. Swipe down from the Status bar with two fingers to open the Quick Access panel, and then touch .
2. Touch **About phone**.
3. Scroll to view the following information:
  - Battery information
  - SW components
  - Legal information
  - Android version
    - Android security update
    - Google Play system update
    - Kernel version
    - Build number

## Determining the Serial Number

Before contacting Customer Support, determine the serial number of your device.

1. Touch **About phone**.
2. Touch **Model & hardware**.

# Getting Started

This section describes the features of the device and explains how to install and charge the battery and how to reset the device.

## Unpacking the Device

1. Carefully remove all protective material from the device and save the shipping container for later storage and shipping.
2. Verify that box contains all the equipment listed below:
  - TC8300
  - Battery
  - Regulatory Guide.
3. Inspect the equipment for damage. If you are missing any equipment or if you find any damaged equipment, contact Support immediately. See [Service Information](#) on page 21 for contact information.

## Removing the Screen Protective Film

A screen protection film is applied to the device's screen to protect the screen during shipping.

To remove the screen protector, carefully lift the thin film off the display.

## Features

**Figure 1** Front View

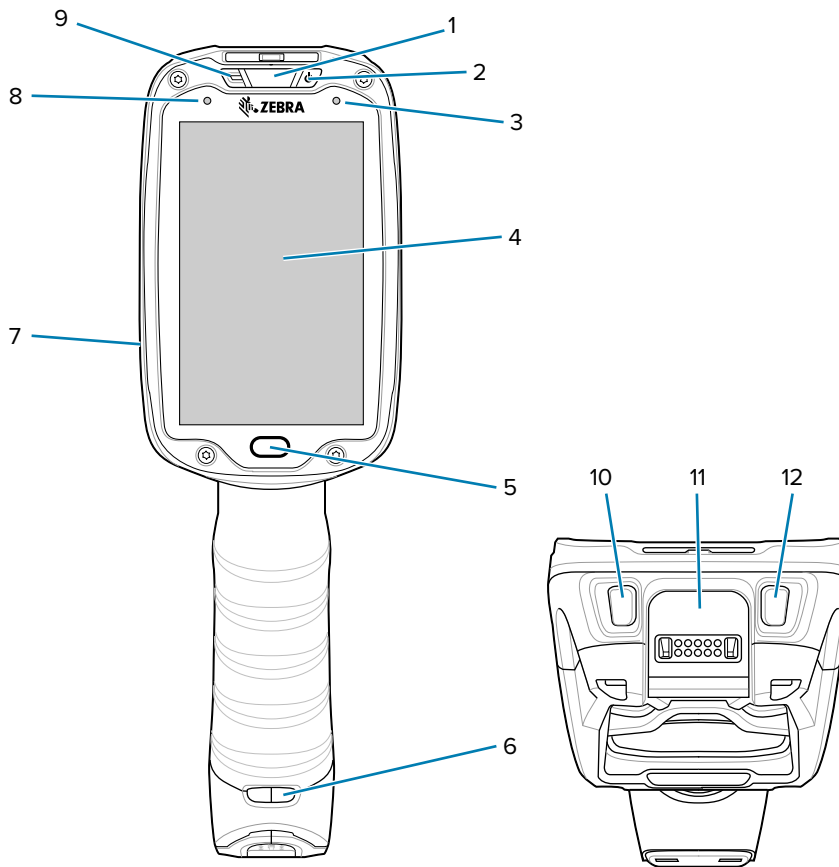

1	Charging/Scan LED	Indicates battery charging status while charging, good decode indication during data capture and application generated notifications.
2	Power Button	Turns the display on and off. Press and hold to reset the device and power off.
3	Blue Indication LED	User programmable LED.
4	Display	Displays all information needed to operate the device.
5	Programmable Button	Press to select items.
6	Hand Strap Mounting Point	Use for installing the optional hand strap.
7	Speakers	Provides audio output for video and music playback.
8	Ambient Light Sensor	Determines ambient light for controlling display backlight intensity.
9	Microphone	Use for communication in Headset mode.
10	Volume Up Button	Increases audio volume (programmable).
11	Interface Connector	Provides USB host and client communication, audio and device charging via cables and accessories.
12	Volume Down Button	Decreases audio volume (programmable).

**Figure 2** Back View

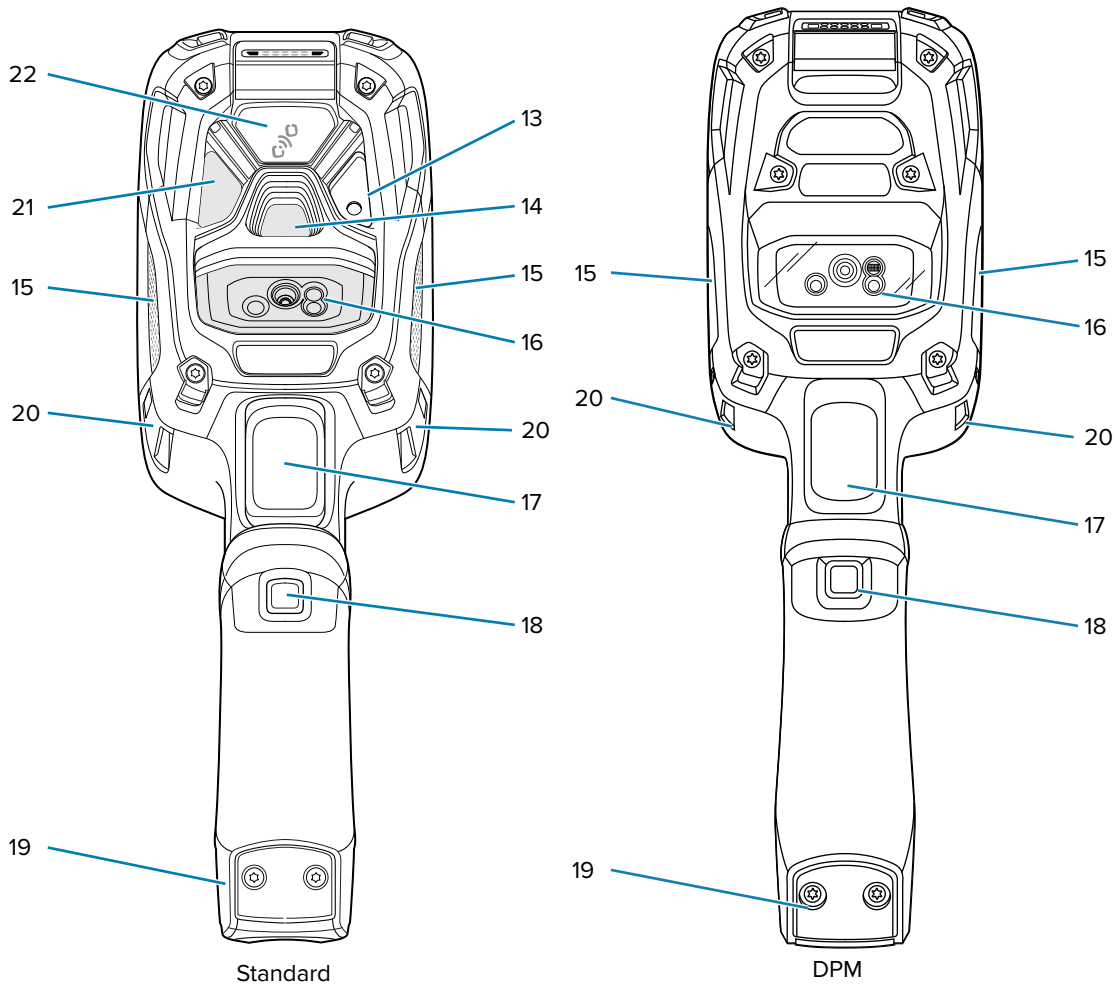

13	Camera Flash	Provides illumination for the camera (optional).
14	Camera	Takes photos and videos (optional).
15	Speaker	Provides audio output.
16	Scanner/Exit Window	Provides data capture using the imager or laser scanner.
17	Trigger	Initiates data capture (programmable).
18	Programmable Button (Secondary Trigger)	Initiates Push-To-Talk communication (programmable).
19	Battery Pack	Provides power to the device.
20	Hand Strap Mounting Point	Use for installing the optional hand strap.
21	Proximity Sensor	Triggers hands-free, triggerless scanning.
22	NFC tag	Tap-to-Pair using NFC (Near Field Communication) - (optional).



## Setting Up the Device

Perform these procedures to start using the device for the first time.

1. Install a microSD card (optional)
2. Install the battery
3. Charge the device
4. Power on the device.

## Installing the microSD Card

The microSD card slot provides secondary non-volatile storage. The slot is located under the back bezel of the unit. Refer to the documentation provided with the card for more information, and follow the manufacturer's recommendations for use.



**WARNING:** Follow proper electrostatic discharge (ESD) precautions to avoid damaging the microSD card. Proper ESD precautions include, but are not limited to, working on an ESD mat and ensuring that the operator is properly grounded.



**NOTE:**

The Condensation Resistant configuration has six screws securing the back bezel.

When installing a microSD card on Condensation Resistant configurations, replace the Back Bezel with desiccant pack. See [Condensation Resistant Rear Bezel Replacement](#) on page 157. Once the Rear Bezel is removed, the desiccant pack absorbs ambient moisture and can lessen the life of the desiccant pack.

1. Remove the Torx T8 screws holding the back bezel in place.

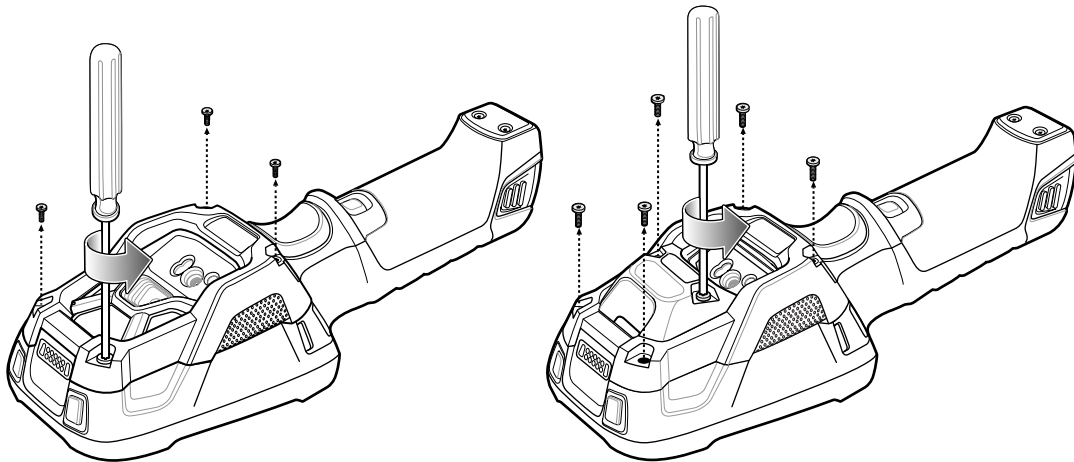

2. Lift the bezel to expose the SD slot.

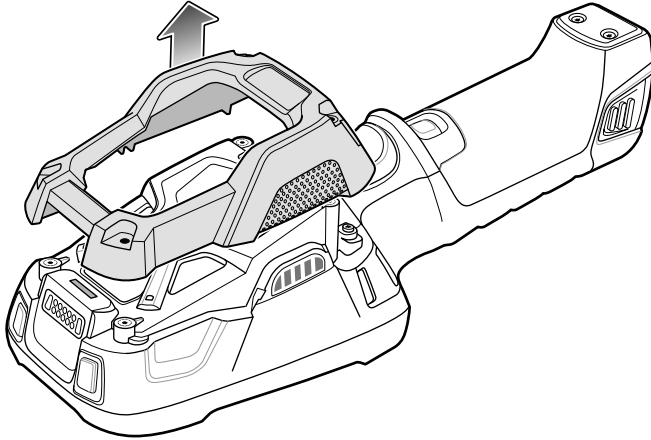

3. Insert the microSD card into the slot with contacts facing the bottom of the device.

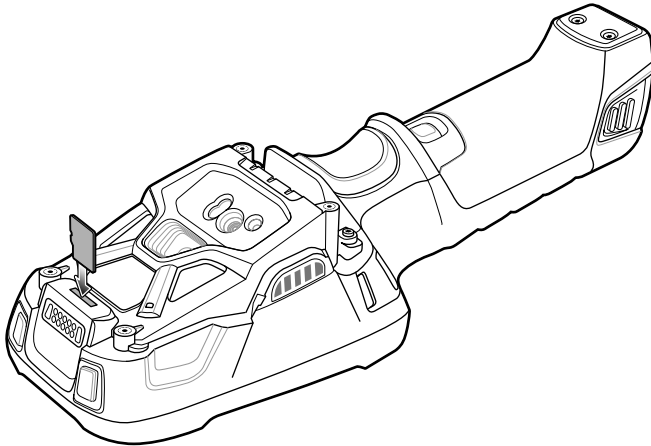

4. Align the bezel onto the device.

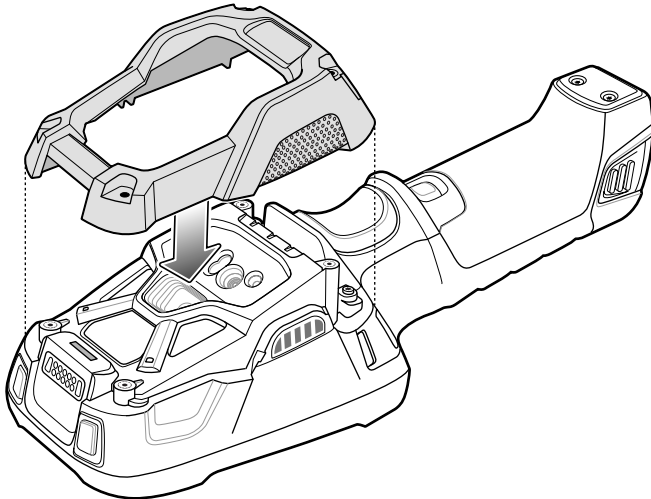

5. Tighten the four screws using T8 hex screwdriver.

6. Torque screws to 4.5 kg-cm.

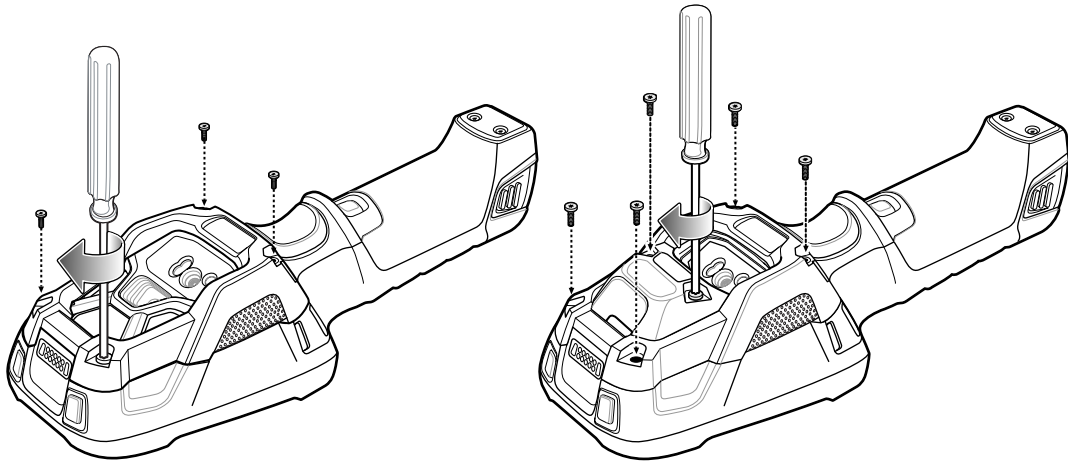

### Installing the Battery

To install the battery:



**NOTE:** The battery is keyed to ensure that the battery is inserted properly. The notch in the battery must face the back of the device.

1. Align the battery with the notch facing the back of the device.

2. Slide the battery into the handle of the device.

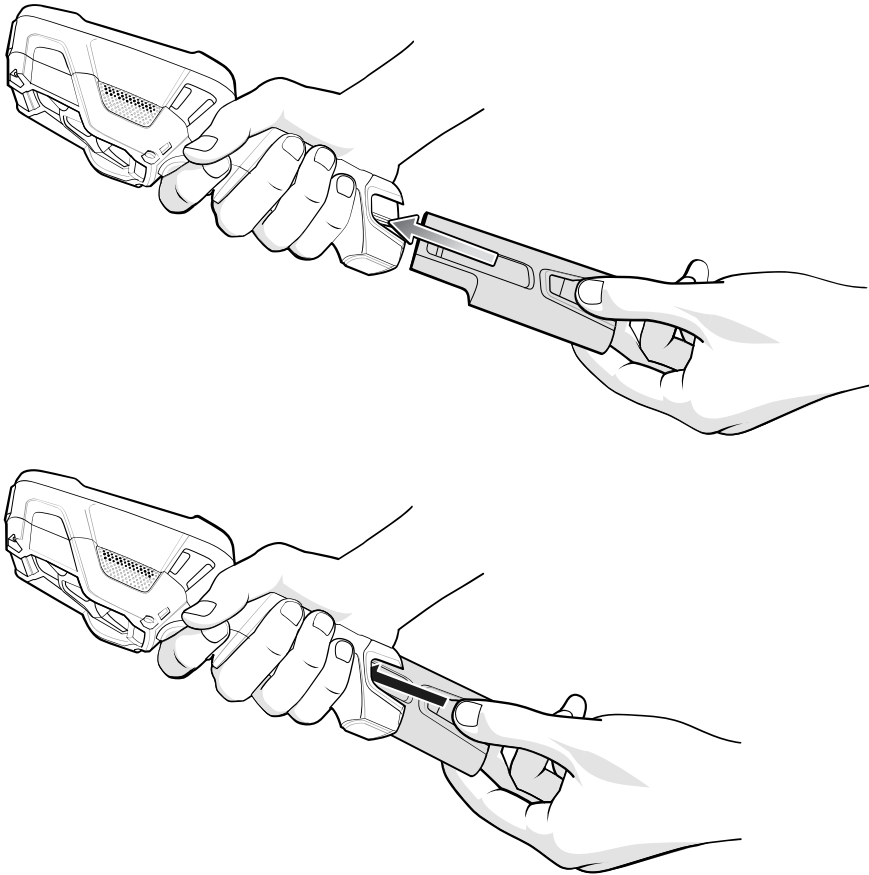

3. Press the battery into the handle until it snaps into place.

## Device Charging

Before using the device for the first time, charge the battery using a cable or a cradle with the appropriate power supply. For information about the accessories available for the device, see [Accessories](#) on page 120.

The device is equipped with a supercapacitor (supercap) which automatically charges from the fully-charged main battery. The supercap requires approximately 10 minutes to fully charge. The supercap retains random access memory (RAM) data in memory and WLAN connection for at least 30 seconds when the main battery is removed during Hot Swap. After 30 seconds, the WLAN connection is dropped and the RAM data is retained for 20 minutes.

- 4-Slot Battery Charger
- 2-Slot USB Charge Cradle
- 5-Slot Charge Only Cradle
- 5-Slot Ethernet Cradle
- 5-Slot Charge Only Cradle with 4-Slot Battery Charger
- 5-Slot Ethernet Cradle with 4-Slot Battery Charger.

The 6,700 mAh battery charges from 0 - 90% in less than four hours at room temperature. The 7,000 mAh battery charges from 0 - 90% in less than five hours at room temperature.

### Charging the Battery

1. To charge the main battery, connect the charging accessory to the appropriate power source.
2. Insert the device into a cradle or attach to a cable. The device turns on and begins charging. The Charging/Scan LED lights amber while charging, then turns solid green when fully charged.

### Charging Temperature

Charge batteries in temperatures from 0 °C to 40 °C (32 °F to 104 °F). The device or accessory always performs battery charging in a safe and intelligent manner. At higher temperatures (e.g. approximately +37 °C (+98 °F)) the device or accessory may for small periods of time alternately enable and disable battery charging to keep the battery at acceptable temperatures. The device or accessory indicates when charging is disabled due to abnormal temperatures via its red blinking LED.

### Charging Indicators

The Charging/Scan LED Indicator indicates the charge status.

**Table 2** Charging/Scan LED Charging Indicators

State	Indication
Off	Device is not charging. Device is not inserted correctly in the cradle or connected to a power source. Charger/cradle is not powered.
Solid Amber	Healthy battery is charging.
Solid Green	Healthy battery charging is complete.
Fast Blinking Red (2 blinks/second)	Charging error, such as: <ul style="list-style-type: none"> <li>• Temperature is too low or too high.</li> <li>• Charging has gone on too long without completion (typically eight hours).</li> </ul>
Solid Red	Unhealthy battery is charging or fully charged.



**IMPORTANT:** When trying to power on the device, a quick blink of the charging LED indicates that it does not have enough battery power to turn on. You will need to charge the battery or replace it.

## Powering on the Device

The device starts automatically as soon as power is applied; either with a charged battery installed or when inserted into the cradle.

If a charged battery is installed and the device is turned off, press the Power button to turn on.

When the device is powered on for the first time, it initializes its system. The splash screen appears for a short period of time.

The splash screen is followed by the boot animation screen and then the **Home Screen**.

## Google Account Setup

The first time the device starts, the Setup Wizard displays. Follow the on-screen instructions to set up a Google account, configure Google Pay™ for purchasing items from the Google Play™ store, to enter your personal information, and enable backup/restore features.



**NOTE:** The device has to be connected to the internet in order to set up a Google™ account. A Google account is only required on devices with GMS software.

## Installing the Hand Strap



**NOTE:** Installation of the hand strap is optional. Skip this section if not installing the hand strap.

1. Remove battery if installed.
2. Thread the lanyard loop through the opening near the base of the handle.

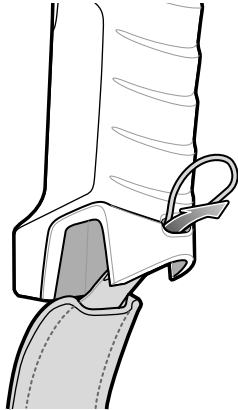

3. Insert the top end of the hand strap through the loop.

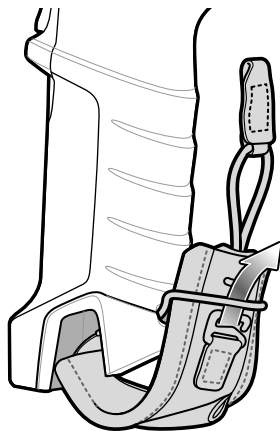

4. Thread the hand-strap through the lanyard.
5. Pull the hand strap through the loop.

6. Thread the lanyard through the slot on the left or right side of the unit, depending on your preference.

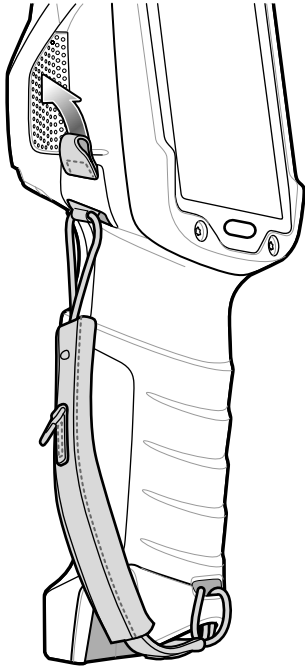

7. Slide the tab onto the clip.

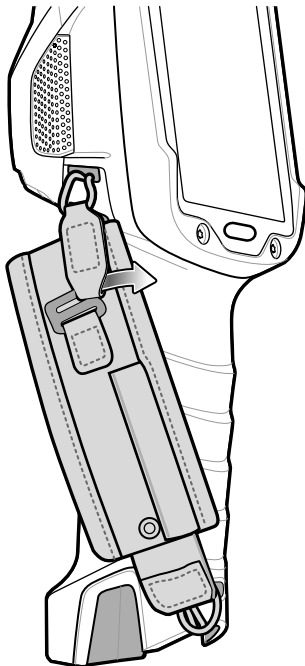

## Hot Swap Mode

The device provides a Hot Swap mode where the user can replace the battery without powering off the device.

When the user removes the battery, the display turns off and the device enters a low power state while in Hot Swap mode. In Hot Swap mode, the device retains RAM data for approximately 5 minutes. Replace

the battery within 5 minutes to preserve memory persistence. If the user does not install a charged battery within 5 minutes, data in RAM will be lost. During Hot Swap mode, Wi-Fi and Bluetooth remain connected for 30 seconds. If the battery is not inserted within 30 seconds, Wi-Fi is disabled and then re-enabled when the device comes out of Hot Swap mode and Bluetooth is reset when the device comes out of Hot Swap mode.



**CAUTION:** To prevent damage to the device, do not perform a hot swap during a device boot up session.



**IMPORTANT:** The supercap requires time to recharge after performing a Hot Swap or after the main battery is fully depleted. Hot Swap mode will not retain data unless the supercap is fully charged.

## Replacing the Battery



**CAUTION:** Do not press the trigger while removing the battery.

1. Do not press the trigger while removing the battery.

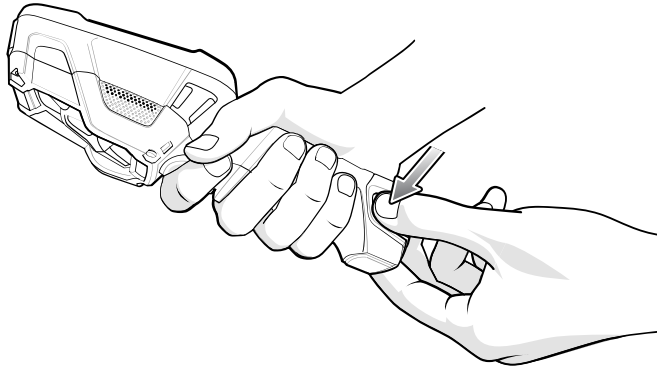



2. Pull the battery out of the device. The Charging/Scan LED lights red.

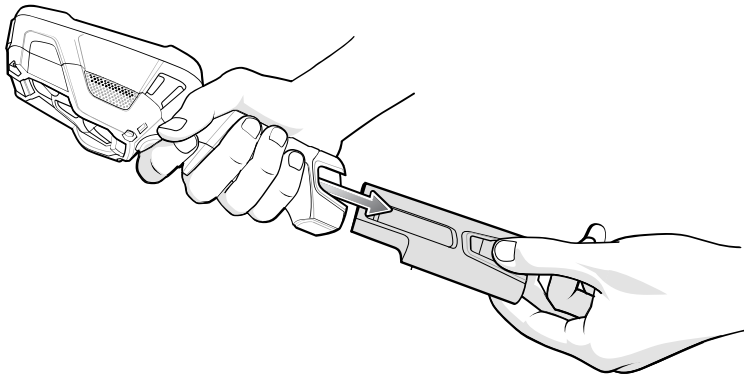
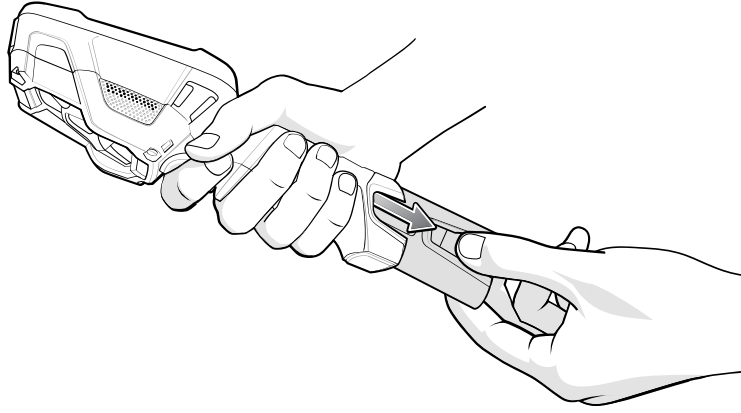

3. Align the replacement battery with the notch facing the back of the device.

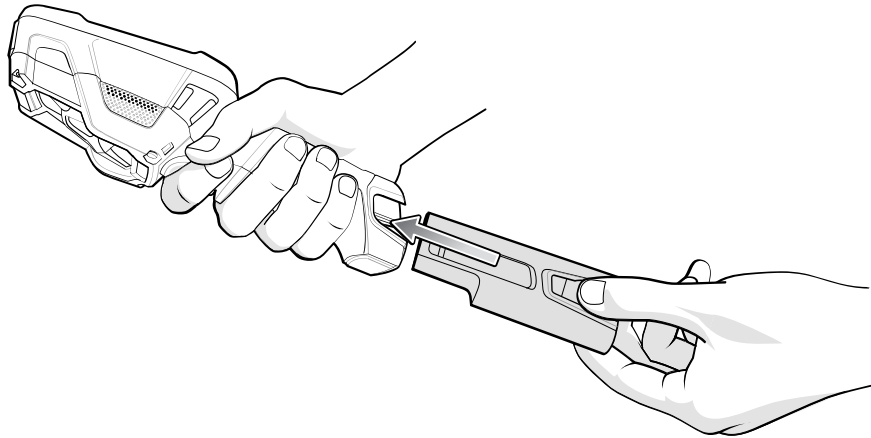

4. Slide the battery into the handle of the device.

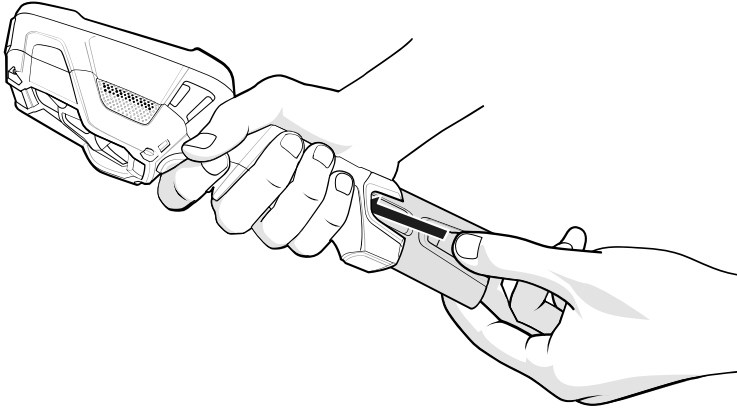

5. Press the battery into the handle until it snaps into place.

# Using the Device

This section explains how to use the device.

## Home Screen

Turn on the device to display the Home screen. Depending on how your system administrator configured your device, your Home screen may appear differently than the graphics in this section.

After a suspend or screen time-out, the Home screen displays with the lock slider. Touch the screen and slide up to unlock. The Home screen provides four additional screens to place widgets and shortcuts. Swipe the screen left or right to view the additional screens.



**NOTE:** By default, AOSP devices do not have the same icons on the Home screen as GMS devices. Icons are shown below for example only.

Home screen icons can be configured by the user and may look different than shown.

**Figure 3** Home Screen

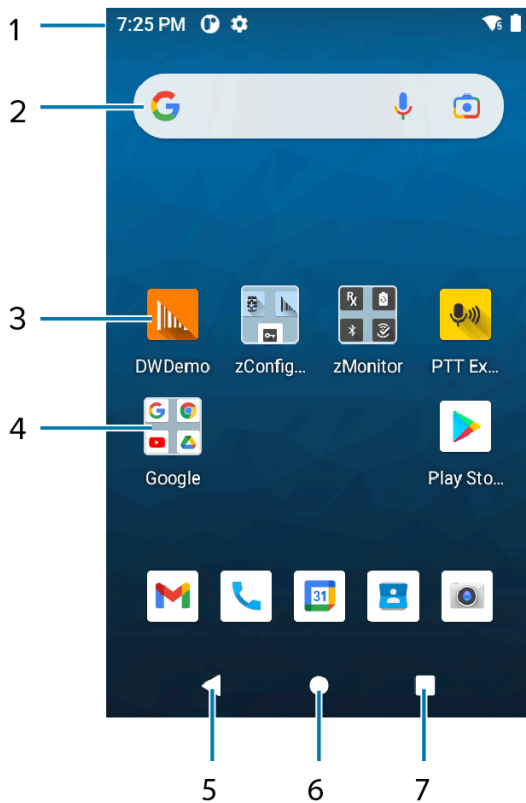

1	Status bar	Displays the time, status icons (right side), and notification icons (left side).
2	Widgets	Launches stand-alone apps that run on the Home screen.
3	Shortcut icons	Opens apps installed on the device.
4	Folder	Contains apps.
5	Back	Displays the previous screen.
6	Home	Displays the home screen.
7	Recent	Displays recently used applications.

## Setting Home Screen Rotation

By default, the Home screen rotation is disabled.



**NOTE:** Auto-rotate must be enabled in the Quick Access panel or in Settings before the Home Screen Rotation setting can be used.

1. Touch and hold anywhere on the Home screen until the options appear.
2. Touch **Home settings**.
3. Touch the **Allow Home screen rotation switch**.
4. Touch **Home**.

5. Rotate the device.

## Status Bar

The Status bar displays the time, notification icons (left side), and status icons (right side).

If there are more notifications than can fit in the Status bar, a dot displays indicating that more notifications exist. Swipe down from the Status bar to open the Notification panel and view all notifications and status.

**Figure 4** Notifications and Status Icons



1	Notification icons
2	Status icons







## Notifications Icons

Notification icons indicate app events and messages.

**Table 3** Notification Icons

Icon	Description
	Main battery is low.
	More notifications are available for viewing.
	Data is syncing.
	Indicates an upcoming event. GMS devices only.
	Open Wi-Fi network is available.
	Audio is playing.
	Problem with sign-in or sync has occurred.
	Device is uploading data.
	Animated: the device is downloading data. Static: the download is complete.









**Table 3** Notification Icons (Continued)

Icon	Description
	Device is connected to or disconnected from a virtual private network (VPN).
	Preparing internal storage by checking it for errors.
	USB debugging is enabled on the device.
	Indicates the RxLogger app is running.
	Indicates the Bluetooth scanner is connected to the device.
	Indicates the ring scanner is connected to the device in HID mode.







## Status Icons

Status icons display system information for the device.

**Table 4** Status Icons

Icon	Description
	Alarm is active.
	Main battery is fully charged.
	Main battery is partially drained.
	Main battery charge is low.
	Main battery charge is very low.
	Main battery is charging.
	All sounds, except media and alarms, are muted. Vibrate mode is active.
	Do Not Disturb mode active.

**Table 4** Status Icons (Continued)

Icon	Description
	Airplane Mode is active. All radios are turned off.
	Bluetooth is on.
	The device is connected to a Bluetooth device.
	Connected to a Wi-Fi network. Indicates the Wi-Fi version number.
	Not connected to a Wi-Fi network or no Wi-Fi signal.
	Connected to an Ethernet network.
	Speakerphone enabled.

## Managing Notifications

Notification icons report the arrival of new messages, calendar events, alarms, and ongoing events. When a notification occurs, an icon appears in the Status bar with a brief description.

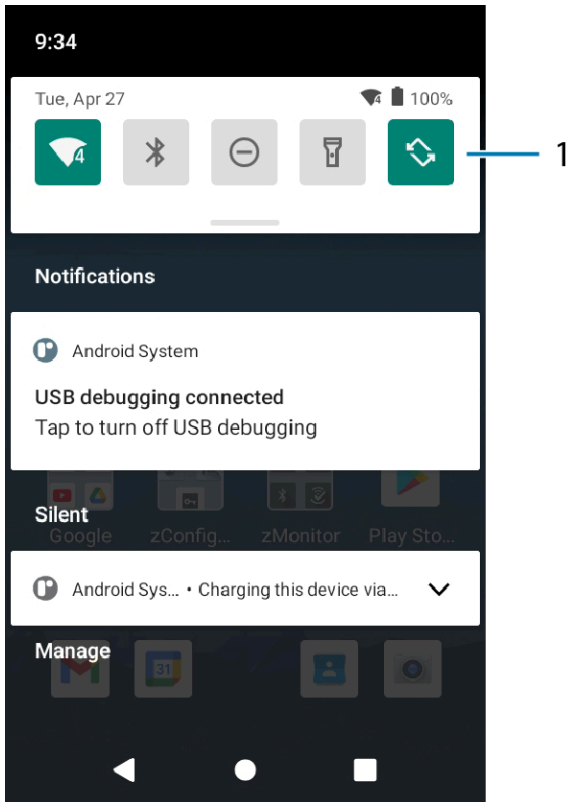

1	Quick settings bar
---	--------------------

- To view a list of all notifications, open the Notification panel by dragging the Status bar down from the top of the screen.
- To respond to a notification, open the Notification panel and then touch a notification. The Notification panel closes and the corresponding app opens.
- To manage recent or frequently used notifications, open the Notification panel and then touch Manage notifications. Touch the toggle switch next to an app to turn off all notifications, or touch an app for more notification options.
- To clear all notifications, open the Notification panel and then touch CLEAR ALL. All event-based notifications are removed. Ongoing notifications remain in the list.
- To close the Notification panel, swipe the Notification panel up.

## Opening the Quick Access Panel

Use the Quick Access panel to access frequently used settings (for example, Airplane mode).



**NOTE:** Not all icons are pictured. Icons may vary.



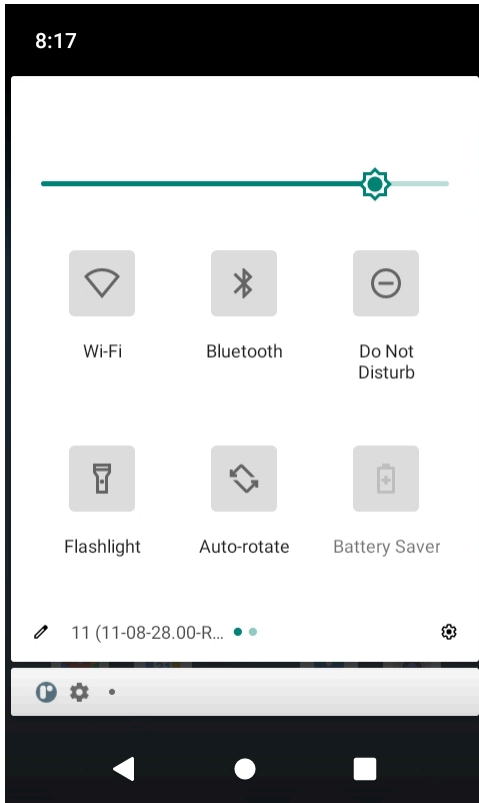





- If the device is locked, swipe down once.
- If the device is unlocked, swipe down once with two fingers, or twice with one finger.
- If the Notification panel is open, swipe down from the Quick Settings bar.













## Quick Access Panel Icons

Quick Access panel icons indicate frequently used settings (for example, Airplane mode).

**Table 5** Quick Access Panel Icons

Icon	Description
	Display brightness - Use the slider to decrease or increase the brightness of the screen.
	Wi-Fi network - Turn Wi-Fi on or off. To open Wi-Fi settings, touch the Wi-Fi network name.
	Bluetooth settings - Turn Bluetooth on or off. To open Bluetooth settings, touch Bluetooth.
	Battery saver - Turn Battery saver mode on or off. When Battery saver mode is on the performance of the device is reduced to preserve battery power (not applicable).

**Table 5** Quick Access Panel Icons (Continued)

Icon	Description
	Invert colors - Invert the display colors.
	Do not disturb - Control how and when to receive notifications.
	Flashlight - Turn flashlight on or off. Turn camera flash on or off. On camera-only devices without an internal scan engine, the flashlight turns off when an app is opened. This ensures the camera is available for scanning.
	Airplane mode - Turn Airplane mode on or off. When Airplane mode is on the device does not connect to Wi-Fi or Bluetooth.
	Auto-rotate - Lock the device's orientation in portrait or landscape mode or set to automatically rotate.
	Night Light - Tint the screen amber to make it easier to look at the screen in dim light. Set Night Light to turn on automatically from sunset to sunrise, or at other times.
	Screen Cast - Share phone content on Chromecast or a television with Chromecast built-in. Touch cast screen to display a list of devices, then touch a device to begin casting.
	Dark Theme - Toggles dark theme on and off. Dark themes reduce the luminance emitted by the screen, while meeting minimum color contrast ratios. It helps improve visual ergonomics by reducing eye strain, adjusting brightness to current lighting conditions, and facilitating screen use in dark environments, while conserving battery power.
	Focus mode - Turn on to pause distracting apps. To open Focus mode settings, touch and hold.
	Bedtime mode - Turn grayscale on and off. Grayscale turns the screen black and white, reducing phone distractions and improving battery life.
	Nearby Share - Helps find and interact with services and devices close to the device.
	Screen Record - Makes a video recording of everything that happens on the screen, with options to include audio and screen touches.
	NFC - Enable or disable NFC communication.

## Editing Icons on the Quick Settings Bar

The first several setting tiles from the Quick Access panel become the Quick Settings bar.

- Open the Quick Access panel and touch  to edit, add, or remove settings tiles.

## Battery Management

Observe the recommended battery optimization tips for the device.



**NOTE:** Before checking the battery charge level, remove the device from any AC power source (cradle or cable).

- Set the screen to turn off after a short period of non-use.
- Reduce screen brightness.
- Turn off all wireless radios when not in use.
- Turn off automatic syncing for Email, Calendar, Contacts, and other apps.
- Minimize use of apps that keep the device from suspending, for example, music and video apps.

## Checking Battery Status

Observe the recommended battery optimization tips for the device.

- Open **Settings** and touch **About phone > Battery Information**. Or, swipe up from the bottom of the screen and touch  to open the **Battery Manager** app.

**Battery present status** indicates if the battery is present.

**Battery level** lists the battery charge (as a percentage of fully charged).

- Swipe down with two fingers from the status bar to open the quick access panel.

Battery percentage is displayed next to the battery icon.

## Monitoring Battery Usage

The Battery screen provides battery charge details and power management options to extend battery life. Different apps display different information. Some apps include buttons that open screens with settings to adjust power use. Use the **DISABLE** or **FORCE CLOSE** buttons to turn off apps that consume too much power.

- Go to **Settings**.
- Touch **Battery**.

To display battery information and power management options for a specific app:

- Go to **Settings**.
- Touch **Apps & notifications > App info**. If there are no recently opened apps, touch **App info** to open the **App Info** screen.
- Touch an app.
- Touch **Advanced > Battery**.

## Low Battery Notification

When the battery charge level drops below the change level in the table below, the device displays a notice to connect the device to power. Charge the battery using one of the charging accessories.

Charge Level Drops Below	Action
15%	The user should charge the battery soon.
10%	The user must charge the battery.
6%	The device turns off. The user must charge the battery.



**NOTE:** Under conditions of heavy load (scanning quickly and often, RF communication, etc.) the device may turn off earlier than 6% charge remaining.

## Turning Off the Radios

1. Swipe down from the Status bar to open the Quick Settings panel.
2. Touch **Airplane mode**.

The airplane icon  appears in the Status bar indicating that all the radios are off.

## Interactive Sensor Technology

To take advantage of these sensors, applications use API commands. Refer to the Google Android Sensor APIs for more information. For information on the Zebra Android EMDK, go to: [techdocs.zebra.com](http://techdocs.zebra.com). The device contains sensors that monitor movement and orientation.

The device contains sensors that monitor movement, orientation, and ambient light.

- Gyroscope - Measures angular rotational velocity to detect rotation of the device.
- Accelerometer - Measures the linear acceleration of movement to detect the orientation of the device.
- Light Sensor - Detects ambient light and adjusts the screen brightness.
- Proximity Sensor - Detects the presence of nearby objects without physical contact. The sensor detects when the device close to your face during a call and turns off the screen, preventing unintentional screen touches.

## Waking The Device

The device goes into Suspend mode when you press **Power** or after a period of inactivity (set in the Display settings window).

1. To wake the device from Suspend mode, press **Power**.

The Lock screen displays.

### 2. Swipe the screen up to unlock.

- If the Pattern screen unlock feature is enabled, the Pattern screen appears instead of the Lock screen.
- If the PIN or Password screen unlock feature is enabled, enter the PIN or password after unlocking the screen.



**NOTE:** If you enter the PIN, password, or pattern incorrectly five times, you must wait 30 seconds before trying again.

- If you forget the PIN, password, or pattern, contact your system administrator.

## USB Communication

Connect the device to a host computer to transfer files between the device and the host computer.

When connecting the device to a host computer, follow the host computer's instructions for connecting and disconnecting USB devices, to avoid damaging or corrupting files.

### Transferring Files

Use Transfer files to copy files between the device and the host computer.

1. Connect the device to a host computer using a USB accessory.
2. On the device, pull down the Notification panel and touch **Charging this device via USB**.  
By default, **No data transfer** is selected.
3. Touch **File Transfer**.
4. On the host computer, open **File Explorer**.
5. Locate the **device** as a portable device.
6. Open the SD card or the Internal storage folder.
7. Copy files to and from the device or delete files as required.

### Transferring Photos

Use PTP to copy photos from the device to the host computer.

1. Connect the device to a host computer using a USB accessory.
2. On the device, pull down the Notification panel and touch **Charging this device via USB**.
3. Touch **PTP**.
4. On the host computer, open a file explorer application.
5. Open the **Internal storage** folder.
6. Copy or delete photos as required.

### Disconnect from the Host Computer



**CAUTION:** Carefully follow the host computer's instructions to disconnect USB devices correctly to avoid losing information.



1. On the host computer, unmount the device.
2. Remove the device from the USB accessory.

# Settings

This section describes the settings on the device.

## Accessing Settings

There are multiple ways to access settings on a device.

- Swipe down with two fingers from the top of the Home screen to open the Quick Access panel and touch .
- Double-swipe down from the top of the Home screen to open the Quick Access panel and touch .
- Swipe up from the bottom of the Home screen to open APPS and touch  **Settings**.

## Display Settings

Use Display settings to change the screen brightness, enable night light, change the background image, enable screen rotation, set sleep time, and change font size.

### Setting the Screen Brightness Manually

Manually set the screen brightness using the touchscreen.

1. Swipe down with two fingers from the Status bar to open the Quick Access panel.
2. Slide the icon to adjust the screen brightness level.



### Setting Night Light

The Night Light setting tints the screen amber, making the screen easier to look at in low light.

1. Go to **Settings**.
2. Touch **Display**.
3. Touch **Night Light**.
4. Touch **Schedule**.

5. Select one of the schedule values:
  - None (default)
  - Turns on at custom time
  - Turns on from sunset to sunrise.
6. By default, **Night Light** is disabled. Touch **TURN ON NOW** to enable.
7. Adjust the tint using the **Intensity** slider.

## Setting Screen Rotation

By default, screen rotation is enabled.



**NOTE:** To change the Home screen rotation, see [Setting Home Screen Rotation](#) on page 36.

1. Go to **Settings**.
2. Touch **Display > Advanced**.
3. Touch **Auto-rotate screen**.

## Setting Screen Timeout

Set the screen sleep time.

1. Go to **Settings**.
2. Touch **Display > Advanced > Sleep**.
3. Select one of the sleep values:
  - **15 seconds**
  - **30 seconds**
  - **1 minute** (default)
  - **2 minutes**
  - **5 minutes**
  - **10 minutes**
  - **30 minutes**

## Setting Ambient Display

The Ambient display setting wakes the screen when notifications are received.

1. Go to Settings.
2. Touch Display > Advanced.
3. Touch Ambient display.
4. In the **When to show** section, enable or disable an option using the switch.



## Setting Font Size

Set the size of the font in system apps.

1. Go to **Settings**.
2. Touch **Display > Advanced**.
3. Touch **Font size**.
4. Select an option to choose how long the touch key light stays on:
  - **Small**
  - **Default**
  - **Large**
  - **Largest**.

## Setting Display Size

By default, display size is set to default.

1. Go to **Settings**.
2. Touch **Display > Advanced**.
3. Touch **Display size**.
4. Touch - and + to change the display size.
  - **Small**
  - **Default**
  - **Large**.

## Setting Touch Panel Mode

The device display is able to detect touches using a finger, a conductive-tip stylus, or gloved finger.



**NOTE:** A glove can be made of medical latex, leather, cotton, or wool. For optimal performance use a Zebra certified stylus.

1. Go to **Settings**.
2. Touch **Display > Advanced**.
3. Touch **TouchPanelUI**.
4. Select:
  - **Finger Only** to use a finger on the screen.
  - **Stylus, Glove and Finger** to use a stylus, gloved finger, or a finger on the screen.

## Setting the Date And Time

You are only required to set the time zone or set the date and time if the wireless LAN does not support Network Time Protocol (NTP).

1. Go to **Settings**.
2. Touch **System** > **Date & time**.
3. Touch **Use network-provided time** to disable automatic date and time synchronization.
4. Touch **Date** to select the date in the calendar.
5. Touch **OK**.
6. Touch **Time**.
  - a) Touch the green circle, drag to the current hour, and then release.
  - b) Touch the green circle, drag to the current minute, and then release.
  - c) Touch **AM** or **PM**.
7. Touch **OK**.
8. Touch **Time zone** > **Time zone** and select the current time zone from the list. This option may not be available in some locations.
9. Touch **Time zone** > **Region** to select the current time zone from the list.
10. Touch **Update Interval** to select an interval to synchronize the system time from the network.
11. In **TIME FORMAT**, choose either **Use local default** or **Use 24-hour format**.

## General Sound Setting

Use the Sound settings to configure media and alarm volumes.

1. Go to **Settings**.
2. Touch **Sound**.
3. Touch an option to set sounds.

## Sound Options

- **Media volume** - Controls the music, games, and media volume.
- **Alarm volume** - Controls the alarm clock volume.
- **Notifications volume** - Controls the notification volume.
- **Do Not Disturb** - Mutes some or all sounds and vibrations.
- **Media** - Shows the media player in Quick Settings while sound is playing, allowing quick access.
- **Shortcut to prevent ringing** - Select how the shortcut method prevents ringing.
- **Default notification sound** - Select a sound to play for all system notifications.
- **Default alarm sound** - Select a sound to play for alarms.

- **Other sounds and vibrations**
  - **Screen locking sounds** - Play a sound when locking and unlocking the screen (default – enabled).
  - **Charging sounds and vibration** - Plays a sound and vibrates when power is applied to the device (default - enabled).
  - **Touch sounds** - Play a sound when making screen selections (default – disabled).
  - **Touch vibration** - Vibrate the device when making screen selections (default – disabled).

## Setting the Wake Up Sources

By default, the device wakes from suspend mode when the user presses the Power button. The device can be configured to wake when the user presses the PTT or Scan buttons on the device handle.

1. Go to **Settings**.
2. Touch **Wake-Up Sources**.
  - **GRIP\_TRIGGER\_2** - PTT button.
  - **SCAN** - Scan button.
3. Touch a checkbox. A check appears in the checkbox.

## Remapping A Button

Buttons on the device can be programmed to perform different functions or as shortcuts to installed apps. For a list of key names and descriptions, refer to: [techdocs.zebra.com](http://techdocs.zebra.com).



**NOTE:** It is not recommended to remap the scan button.

1. Go to **Settings**.
2. Touch **Key Programmer**. A list of programmable buttons displays.
3. Select the button to remap.
4. Touch the **Shortcut**, the **Keys and Buttons**, or the **Trigger** tabs to list the available functions, applications, and triggers.
5. Touch a function or application shortcut to map to the button.



**NOTE:** If you select an application shortcut, the application icon appears next to the button on the Key Programmer screen.

## Keyboards

The device provides multiple keyboard options.



**NOTE:** By default, the Enterprise and Virtual Keyboards are disabled. The Enterprise Keyboard is available for download from the [Zebra Support Site](http://Zebra Support Site).

- Android Keyboard - AOSP devices only
- Gboard - GMS devices only
- Enterprise Keyboard

## Keyboard Configuration



This section describes configuring the device's keyboard.

### Enabling Keyboards

1. Go to **Settings**.
2. Touch **System** > **Languages & input** > **On-screen keyboard** > **Manage on-screen keyboards**.
3. Touch a keyboard to enable.

### Switching Between Keyboards

To switch between keyboards, touch in a text box to display the current keyboard.

1. On the Gboard keyboard, touch and hold  (GMS devices only).
2. On the Enterprise keyboard, touch . Only available with Mobility DNA Enterprise License. Not pre-installed on the device. Contact Zebra Support for more information.

## Using the Android and Gboard Keyboards

Use the Android or Gboard keyboards to enter text in a text field.

- To configure the keyboard settings, touch and hold "," (comma) and then select **Android keyboard settings**.

### Edit Text

Edit entered text and use menu commands to cut, copy, and paste text within or across apps. Some apps do not support editing some or all of the text they display; others may offer their own way to select text.

### Entering Numbers, Symbols, and Special Characters

1. Enter numbers and symbols.
  - Touch and hold one of the top-row keys until a menu appears then select a number or special character.
  - Touch the Shift key once for a single capital letter. Touch the Shift key twice to lock in uppercase. Touch the Shift key a third time to unlock Capslock.
  - Touch **?123** to switch to the numbers and symbols keyboard.
  - Touch the **=\<** key on the numbers and symbols keyboard to view additional symbols.
2. Enter special characters.
  - Touch and hold a number or symbol key to open a menu of additional symbols. A larger version of the key displays briefly over the keyboard.

## Enterprise Keyboard

The Enterprise Keyboard contains multiple keyboard types.

- Numeric
- Alpha
- Special characters
- Data capture.

### Numeric Tab

The numeric keyboard is labeled **123**. The keys displayed vary on the app being used. For example, an arrow displays in **Contacts**, however **Done** displays in **Email** account setup.

### Alpha Tab

The alpha keyboard is labeled using the language code. For English, the alpha keyboard is labeled **EN**.

### Additional Character Tab

The additional characters keyboard is labeled **#\*/**.

- Touch  to enter emoji icons in a text message.
- Touch **ABC** to return to the Symbols keyboard.

### Scan Tab

The Scan tab provides an easy data capture feature for scanning barcodes.

## Language Usage

Use the **Language & input** settings to change the device's language, including words added to the dictionary.

### Changing the Language Setting

1. Go to **Settings**.
2. Touch **System > Languages & input**.
3. Touch **Languages**. A list of available languages displays.
4. If the desired language is not listed, touch **Add a language** and select a language from the list.
5. Touch and hold  to the right of the desired language, then drag it to the top of the list.
6. The operating system text changes to the selected language.

## Adding Words to the Dictionary

1. Go to **Settings**.
2. Touch **System > Languages & input > Advanced > Personal dictionary** .
3. If prompted, select the language where this word or phrase is stored.
4. Touch + to add a new word or phrase to the dictionary.
5. Enter the word or phrase.
6. In the Shortcut text box, enter a shortcut for the word or phrase.

## Notifications

The user can configure notifications for the device and for specific apps. Device notifications settings allow the user to configure how notifications occur on the device. App notification settings allow the user to configure how notifications for a specific app occur.

To view device notification settings, touch **Settings > Apps & notifications > Notifications**. To view app notifications, **Settings > Apps & notifications > App info**, and then select an app.

## Setting App Notifications

Configure the notifications settings for a specific app.

1. Go to **Settings**.
2. Touch **Apps & notifications > App info**.  
If there are no recently opened apps, touch **App info** to open the **App Info** screen.
3. Select an app.  
Options vary depending on the app selected.

#### 4. Select an available option:

- **Open** - Opens the app.
- **Disable** - Turn the app off and hide it. The app no longer appears in the All Apps list. You must re-enable the app to use it.
- **Force Stop** - Turn off the app.
- **Notifications**
  - **All app notifications** - Select to turn all notifications from this app on (default) or off. Touch a notification category to display additional options.
  - **Default** - Allow notifications from this app to make sound or vibrate the device.
  - **Silent** - Do not allow notifications from this app to make sound or vibrate.
  - **Minimize** - In the Notification panel, collapse notifications to one line.
  - **Advanced** - Touch for additional options.
    - **Allow notification dot** - Do not allow this app to add a notification dot to the app icon.
    - **Additional settings in the app** - Open the app settings.
  - **Permissions** - Configure which permissions are allowed or denied for this app.
  - **Storage & cache** - View the amount of storage and cache space used for this app. You can choose to **Clear Storage** and **Clear Cache** for the app to free up storage space on the device.
  - **Mobile data & Wi-Fi** - View the data usage for this app. You can choose to enable Background data usage or allow Unrestricted data usage by this app.
  - **Advanced** - Touch for additional options.
  - **Screen time** - Touch for options to set an App timer that limits the amount of time you can use this app and to Manage notifications.
  - **Battery** - Set Background restriction and Battery optimization for this app.
  - **Open by default** - Modify which links or files the app opens by default.
- **Advanced**
  - **Picture-in-picture** - Allow this app to create a picture-in-picture window when the app is running in the background.
  - **Install unknown apps** - Allow this app to install unknown apps.
  - **Display over other apps** - Allow this app to display over other apps.
  - **Modify system settings** - Allow this app to modify system settings.
- **Store**
  - **App details** - Opens the Google Play Store to display information about the app.

## Viewing Notifications

1. Go to **Settings**.
2. Touch **Apps & Notifications**.
3. Scroll down to **Notifications** to view how many apps have notifications turned off.

### Controlling Lock Screen Notifications

Control whether notifications can be seen when the device is locked.

1. Go to **Settings**.
2. Touch **Apps & notifications > Notifications** .
3. Touch **Notifications on lockscreen** and select one of the following:
  - **Show conversation, default, and silent**
  - **Hide silent conversation and notifications**
  - **Don't show any notifications**

### Enabling Blink Light

The Notification LED lights blue when an app, such as email and VoIP, generates a programmable notification or to indicate when the device is connected to a Bluetooth device. By default, LED notifications are enabled.

1. Go to **Settings**.
2. Touch **Apps & notifications > Notifications > Advanced** .
3. Touch **Blink light** to toggle the notification on or off.









# Applications

Apart from the standard pre-installed Android applications, the following table lists Zebra-specific applications installed on the device.







## Installed Applications

Aside from the common Google apps, the Zebra-specific apps that are installed on the device are described in this section.

**Table 6** Apps

Icon	Description
	<b>Battery Manager</b> - Displays battery information, including charge level, status, health and wear level.
	<b>Bluetooth Pairing Utility</b> – Use to pair a Zebra Bluetooth scanner with the device by scanning a barcode.
	<b>DataWedge</b> - Enables data capture using the imager.
	<b>DWDemo</b> - Provides a way to demonstrate the data capture features using the imager.
	<b>License Manager</b> - Use to manage software licenses on the device.
	<b>Phone</b> - Use to dial a phone number when used with some Voice over IP (VoIP) clients (VoIP telephony ready only).
	<b>PTT Express</b> - Use to launch PTT Express client for VoIP communication.

**Table 6** Apps (Continued)

Icon	Description
	<b>RxLogger</b> - Use to diagnose device and app issues.
	<b>Settings</b> - Use to configure the device.
	<b>StageNow</b> - Allows the device to stage a device for initial use by initiating the deployment of settings, firmware, and software.
	<b>Velocity</b> - Opens the Ivanti (formerly Wavelink) terminal emulation app.
	<b>VoD</b> - The Video on Device basic app provides a how-to video for proper device cleaning. For Video on Device licensing information, go to <a href="http://learning.zebra.com">learning.zebra.com</a> .
	<b>Worry Free Wifi Analyzer</b> - A diagnostic intelligent app. Use to diagnose surrounding area and display network stats, such as coverage hole detection, or AP in the vicinity. Refer to the Worry Free Wi-Fi Analyzer Administrator Guide for Android.
	<b>Zebra Bluetooth Settings</b> - Use to configure Bluetooth logging.

## Accessing Apps

Access all apps installed on the device using the APPS window.

1. On the Home screen, swipe up from the bottom of the screen.
2. Slide the **APPS** window up or down to view more app icons.
3. Touch an icon to open the app.

## Switching Between Recent Apps

1. Touch **Recent**.  
A window appears on the screen with icons of recently used apps.
2. Slide the apps displayed up and down to view all recently used apps.
3. Swipe left or right to remove the app from the list and force close the app.
4. Touch an icon to open an app or touch Back to return to the current screen.

## Battery Manager

The Battery Manager provides detailed information about the battery.

This section also provides battery swap procedures for supported devices.



### Opening Battery Manager

- To open the Battery Manager app, swipe up from the bottom of the Home screen, and then touch .

### Battery Manager Information

The Battery Manager displays detailed information about battery charging, health, and status.

**Table 7** Battery Icons

Battery Icon	Description
	Battery charge level is between 85% and 100%.
	Battery charge level is between 19% and 84%.
	Battery charge level is between 0% and 18%.

- Level** - The current battery charge level as a percentage. Displays -% when the level is unknown.
- Wear** - The health of the battery in graphical form. When the wear level exceeds 80%, the bar color changes to red.
- Health** - The health of the battery. If a critical error occurs,  appears. Touch to view the error description.
  - Decommission** - The battery is past its useful life and should be replaced. See system administrator.
  - Good** - The battery is good.
  - Charge error** - An error occurred while charging. See system administrator.
  - Over Current** - An over-current condition occurred. See system administrator.
  - Dead** - The battery has no charge. Replace the battery.
  - Over Voltage** - An over-voltage condition occurred. See system administrator.
  - Below Temperature** - The battery temperature is below the operating temperature. See system administrator.
  - Failure Detected** - A failure has been detected in the battery. See system administrator.
  - Unknown** - See system administrator.

- **Charge Status**
  - **Not charging** - The device is not charging.
  - **Charging-AC** - The device is connected to AC power and charging.
  - **Discharging** - The battery is discharging.
  - **Full** - The battery is fully charged.
  - **Unknown** - The battery status is unknown.
- **Time until Full** - The amount of time until the battery is fully charged.
- **Time since charging** - The amount of time since the device began charging.
- **Time until empty** - The amount of time until the battery is empty.

- **Advanced info** - Touch to view additional battery information.
  - **Battery present status** - Indicates that the battery is present.
  - **Battery level** - The battery charge level as a percentage of scale.
  - **Battery scale** - The battery scale level used to determine battery level (100).
  - **Battery voltage** - The current battery voltage in millivolts.
  - **Battery temperature** - The current battery temperature in degrees Centigrade.
  - **Battery technology** - The type of battery.
  - **Battery current** - The average current into or out of the battery over the last second in mAh.
  - **Battery manufacture date** - The date of manufacture.
  - **Battery serial number** - The battery serial number. The number matches the serial number printed on the battery label.
  - **Battery part number** - The battery part number.
  - **Battery decommission status** - Indicates if the battery is past its life span.
    - **Good** - The battery is in good health.
    - **Decommissioned Battery** - The battery is past its useful life and should be replaced.
  - **Base cumulative charge** - Cumulative charge using Zebra charging equipment only.
  - **Battery present capacity** - Maximum amount of charge that could be pulled from the battery under the present discharge conditions if the battery were fully charged.
  - **Battery health percentage** - With a range from 0 to 100, this is the ratio of “present\_capacity” to “design\_capacity” at a discharge rate of “design\_capacity”.
  - **Usage decommission threshold** - When the Battery usage number is greater than or equal to the Usage decommission threshold, the battery is past its useful life and should be replaced.
  - **% decommission threshold** - The default % decommission threshold for a gifted battery as 80%.
  - **Battery present charge** - Amount of usable charge remaining in the battery at present under the current discharge conditions.
  - **Battery total cumulative charge** - The total accumulated charge in all chargers.
  - **Battery time since first use** - The time passed since the battery was placed in a Zebra terminal for the first time.
  - **Battery error status** - The error status of the battery.
  - **App version** - The application version number.

## Camera

This section provides information for taking photos and recording videos using the integrated digital cameras.

## Taking Photos

1. Swipe up from the bottom of the Home screen and touch **Camera**.

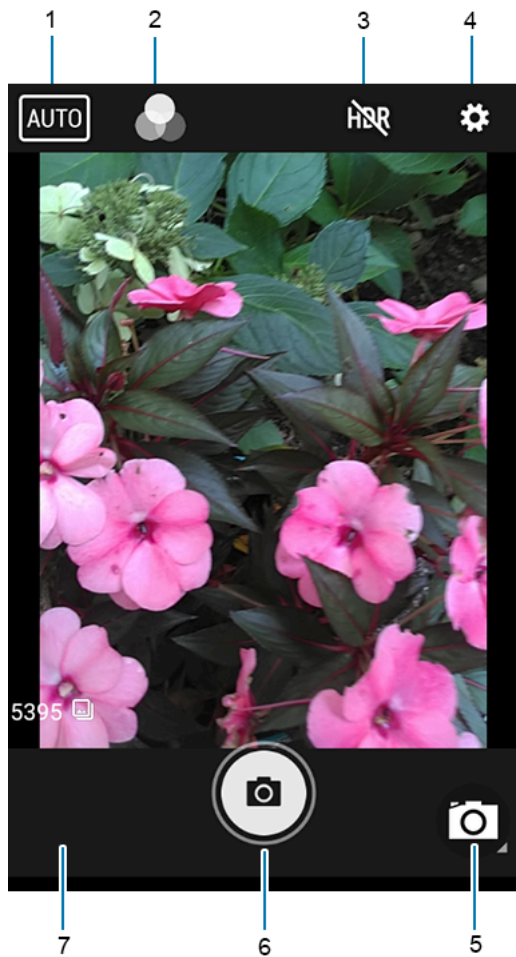

1	Scene mode
2	Color effect
3	High dynamic range
4	Settings
5	Camera mode
6	Shutter button
7	Gallery

2. If necessary, touch the Camera Mode icon and touch .
3. Frame the subject on the screen.
4. To zoom in or out, press two fingers on the display and pinch or expand your fingers. The zoom controls appear on the screen.
5. Touch an area on the screen to focus. The focus circle appears. The two bars turn green when in focus.

6. Touch .

The camera takes a photo and a shutter sound plays.

The photo momentarily displays as a thumbnail in the lower-left corner.

## Taking a Panoramic Photo

Panorama mode creates a single wide image by panning slowly across a scene.

1. Swipe up from the bottom of the Home screen and touch **Camera**.



2. Touch the Camera Mode icon and touch .

3. Frame one side of the scene to capture.

4. Touch  and slowly pan across the area to capture. A small white square appears inside the button indicating the capture is in progress.

If you are panning too quickly, the message **Too fast** appears.

5. Touch  to end the shot. The panorama appears immediately and a progress indicator displays while it saves the image.



## Recording Videos

1. Swipe up from the bottom of the Home screen and touch **Camera**.

2. Touch the camera mode menu and touch .



1	Color effect
2	Audio
3	Settings
4	Camera mode
5	Shutter button
6	Gallery

3. Point the camera and frame the scene.
4. To zoom in or out, press two fingers on the display and pinch or expand fingers. The zoom controls appear on the screen.
5. Touch  to start recording.  
The video time remaining appears in the top left of the screen.
6. Touch  to end the recording.  
The video momentarily displays as a thumbnail in the lower left corner.





## Photo Settings

In Photo mode, photo settings appear on screen.





Touch  to display the photo settings options.

### Rear Camera Photo Settings

- **Flash** - Select whether the camera relies on its light meter to decide whether a flash is necessary, or to turn it on or off for all shots.

Icon	Description
	<b>Off</b> - Disable flash.
	<b>Auto</b> - Adjust flash automatically depending upon light meter (default).
	<b>On</b> - Enable flash upon taking a photo.

- **Picture size** - The size (in pixels) of the photo to: 13M pixels (default), 8M pixels, 5M pixels, 3M pixels, HD 1080, 2M pixels, HD720, 1M pixels, WVGA, VGA, or QVGA.
- **Picture quality** - Set the picture quality setting to: Low, Standard (default) or High.
- **Storage** – Set the location to store the photo to: Phone or SD Card.
- **ISO** - Set camera sensitivity to light to: Auto (default), ISO Auto (HJR), ISO100, ISO200, ISO400, ISO800 or ISO1600.
- **Exposure** - Set the exposure settings to: +2, +1, 0(default), -1 or -2.
- **White balance** - Select how the camera adjusts colors in different kinds of light, to achieve the most natural-looking colors.

Icon	Description
	<b>Incandescent</b> - Adjust the white balance for incandescent lighting.
	<b>Fluorescent</b> - Adjust the white balance for florescent lighting.
	<b>Auto</b> - Adjust the white balance automatically (default).
	<b>Daylight</b> - Adjust the white balance for daylight.
	<b>Cloudy</b> - Adjust the white balance for a cloudy environment.

- **Chroma Flash** - Sets the camera to take two pictures, one with flash and one without flash. The two images are combined to produce a final image with the sharpness and clarity and bright color tones

from a picture with the flash, coupled with the natural colors of a picture without a flash. Options: Off (default) or On.



- **Redeye reduction** - Helps eliminate redeye effect. Options: Disabled (default), or Enable.
- **ZSL** - Set the camera to immediately take a picture when the button is pressed (default – enabled).
- **Shutter Sound** - Select to play a shutter sound when taking a photo. Options: Disable (default) or Enable.
- **Anti Banding** - Allows the camera to avoid problems caused by artificial light sources that are not constant. These sources cycle (flicker) fast enough to go unnoticed to the human eye, appearing continuous. The camera’s eye (its sensor) can still see this flicker. Options: Auto (default), 60 Hz, 50 Hz, or Off.

## Video Settings





In Video mode, video settings appear on screen. Touch  to display the video settings options.

### Rear Camera Video Settings

- **Flash** - Select whether Rear-facing Camera relies on its light meter to decide whether a flash is necessary, or to turn it on or off for all shots.

Icon	Description
	<b>Off</b> - Disable flash.
	<b>On</b> - Enable flash upon taking a photo.

- **Video quality** - Set video quality to: 4k DCI, 4k UHD, HD 1080p (default), HD 720p, SD 480p, VGA, CIF, or QVGA.
- **Video duration** - Set to: 30 seconds (MMS) or 30 minutes (default).
- **Storage** – Set the location to store the photo to: Phone (default) or SD Card.
- **White balance**- Select how the camera adjusts colors in different kinds of light, to achieve the most natural-looking colors.

Icon	Description
	<b>Incandescent</b> - Adjust the white balance for incandescent lighting.
	<b>Fluorescent</b> - Adjust the white balance for florescent lighting.
	<b>Auto</b> - Adjust the white balance automatically (default).
	<b>Daylight</b> - Adjust the white balance for daylight.

Icon	Description
	<b>Cloudy</b> - Adjust the white balance for a cloudy environment.

- **Image Stabilization** - Set to reduce blurry videos due to device movement. Options: On or Off (default).

## DWDemo







Use DataWedge Demonstration (DWDemo) to demonstrate data capture functionality. To configure DataWedge, refer to [techdocs.zebra.com/datawedge/](http://techdocs.zebra.com/datawedge/).



**NOTE:** DataWedge is enabled on the Home screen. To disable this feature, go to the DataWedge settings and disable the **Launcher** profile.

## Datawedge Demonstration Icons

**Table 8** DataWedge Demonstration Icons

Category	Icon	Description
Illumination		Imager illumination is on. Touch to turn illumination off.
Illumination		Imager illumination is off. Touch to turn illumination on.
Data Capture		A Bluetooth scanner is connected.
Data Capture		A Bluetooth scanner is not connected.
Scan Mode		Imager is in picklist mode. Touch to change to normal scan mode.
Scan Mode		Imager is in normal scan mode. Touch to change to picklist mode.
Menu		Opens a menu to view the application information or to set the application DataWedge profile.

## Selecting a Scanner

See [Data Capture](#) on page 73 for more information.

1. To select a scanner, touch  > **Settings** > **Scanner Selection**.
2. Press the programmable button or touch the yellow scan button to capture data.  
The data appears in the text field below the yellow button.

## PTT Express Voice Client

PTT Express Voice Client enables Push-To-Talk (PTT) communication between disparate enterprise devices. Leveraging existing Wireless Local Area Network (WLAN) infrastructure, PTT Express delivers simple PTT communication without requiring a voice communication server.



**NOTE:** Requires a PTT Express License.

- **Group Call** - Press and hold **PTT (Talk)** to start communicating with other voice client users.
- **Private Response** - Double-press **PTT** to respond to the originator of the last broadcast or to make a Private Response.

Refer to the PTT Express User Guide at [zebra.com/support](http://zebra.com/support) for information on configuring the PTT Express Client application.

## PTT Express User Interface

Use the PTT Express interface for Push-To-Talk communication.

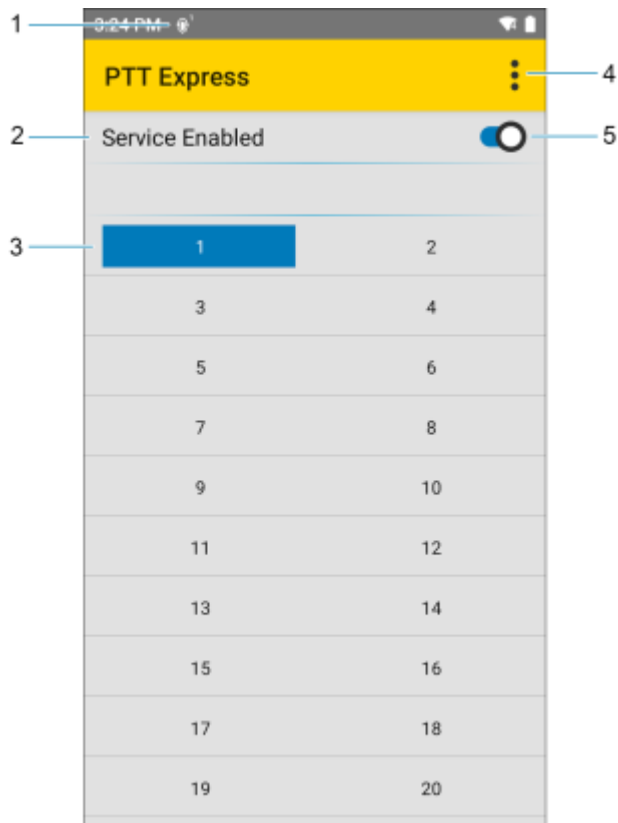

Number	Item	Description
1	Notification icon	Indicates the current state of the PTT Express client.
2	Service indication	Indicates the status of the PTT Express client. Options are: Service Enabled, Service Disabled or Service Unavailable.
3	Talk group	Lists all 32 Talk Groups available for PTT communication.

Number	Item	Description
4	Settings	Opens the PTT Express Settings screen.
5	Enable/disable switch	Turns the PTT service on and off.

## PTT Audible Indicators







The following tones provide helpful cues when using the voice client.

- **Talk Tone:** Double chirp. Plays when the Talk button is depressed. This is a prompt for you to start talking.
- **Access Tone:** Single beep. Plays when another user just finished a broadcast or response. You can now initiate a Group Broadcast or Private Response.
- **Busy Tone:** Continuous tone. Plays when the Talk button is depressed and another user is already communicating on the same talkgroup. Plays after the maximum allowed talk time is reached (60 seconds).
- **Network Tone:**
  - Three increasing pitch beeps. Plays when PTT Express acquires the WLAN connection and the service is enabled.
  - Three decreasing pitch beeps. Plays when PTT Express loses the WLAN connection or the service is disabled.

## PTT Notification Icons

Notification icons indicate the current state of the PTT Express Voice client.

**Table 9** PTT Express Icons

Status Icon	Description
	The PTT Express Voice client is disabled.
	The PTT Express Voice client is enabled but not connected to a WLAN.
	The PTT Express Voice client is enabled, connected to a WLAN, and listening on the Talk Group indicated by the number next to the icon.
	The PTT Express Voice client is enabled, connected to a WLAN, and communicating on the Talk Group indicated by the number next to the icon.
	The PTT Express Voice client is enabled, connected to a WLAN, and in a private response.
	The PTT Express Voice client is enabled and muted.
	The PTT Express Voice client is enabled but it is not able to communicate due to a VoIP telephony call in progress.

## Enabling PTT Communication

1. Swipe up from the bottom of the Home screen and touch .
2. Slide the Enable/Disable Switch to the **ON** position. The button changes to **ON**.

## Selecting a Talk Group

There are 32 Talk Groups that can be selected by PTT Express users. However, only one talk group can be enabled at a time on the device.

- Touch one of the 32 Talk Groups. The selected Talk Group is highlighted.

## PTT Communication

This section describes the default PTT Express client configuration. Refer to the PTT Express V1.2 User Guide for detailed information on using the client.

### Creating Group Call

1. Press and hold **PTT** (1) (or **Talk** on the headset) and listen for the talk tone.  
If you hear a busy tone, release the button and wait a moment before making another attempt. Ensure that PTT Express and the WLAN are enabled.



**NOTE:** Holding the button for more than 60 seconds (default) drops the call, allowing others to make Group calls. Release the button when finished talking to allow others to make calls.

2. Start talking after hearing the talk tone.
3. Release the button when finished talking.

### Responding with a Private Response

The Private Response can only be initiated once a Group Call has been established. The initial Private Response is made to the originator of the Group Call.

1. Wait for an access tone.
2. Within 10 seconds, double-press **PTT**, and listen for the talk tone.
3. If you hear a busy tone, release the button and wait a moment before making another attempt. Ensure that PTT Express and the WLAN are enabled.
4. Start talking after the talk tone plays.
5. Release the button when finished talking.

## Disabling PTT Communication

1. Swipe up from the bottom of the Home screen and touch .
2. Slide the **Enable/Disable Switch** to the **OFF** position. The button changes to **OFF**.

## Rxlogger

RxLogger is a comprehensive diagnostic tool that provides application and system metrics, and diagnoses device and application issues.

RxLogger logs the following information: CPU load, memory load, memory snapshots, battery consumption, power states, wireless logging, cellular logging, TCP dumps, Bluetooth logging, GPS logging, logcat, FTP push/pull, ANR dumps, etc. All generated logs and files are saved onto flash storage on the device (internal or external).

### RxLogger Configuration

RxLogger is built with an extensible plug-in architecture and comes packaged with a number of plug-ins already built-in. For information on configuring RxLogger, refer to [techdocs.zebra.com/rxlogger/](http://techdocs.zebra.com/rxlogger/).

To open the configuration screen, from the RxLogger home screen touch **Settings**.

### Configuration File

RxLogger configuration can be set using an XML file.

The config.xml configuration file is located in the RxLogger\config folder. Copy the file from the device to a host computer using a USB connection. Edit the configuration file and then replace the XML file on the device. There is no need to stop and restart the RxLogger service since the file change is automatically detected.

### Enabling Logging

1. Swipe the screen up and select .
2. Touch **Start**.

### Disabling Logging

1. Swipe the screen up and select .
2. Touch **Stop**.

### Extracting Log Files

1. Connect the device to a host computer using an USB connection.
2. Using a file explorer, navigate to the RxLogger folder.
3. Copy the file from the device to the host computer.
4. Disconnect the device from the host computer.

### Backing Up Data

RxLogger Utility allows the user to make a zip file of the RxLogger folder in the device, which by default contains all the RxLogger logs stored in the device.

- To save the backup data, touch  > **BackupNow**.

## RxLogger Utility

RxLogger Utility is a data monitoring application for viewing logs in the device while RxLogger is running. Logs and RxLogger Utility features are accessed using Main Chat Head.

### Initiating the Main Chat Head

1. Open **RxLogger**.
2. Touch  > **Toggle Chat Head**.  
The Main Chat Head icon appears on the screen.
3. Touch and drag the Main Chat head icon to move it around the screen.

### Removing the Main Chat Head

1. Touch and drag the icon.  
A circle with an X appears.
2. Move the icon over the circle and then release.

### Viewing Logs

1. Touch the Main Chat Head icon.  
The RxLogger Utility screen appears.
2. Touch a log to open it.  
The user can open many logs with each displaying a new sub Chat Head.
3. If necessary, scroll left or right to view additional Sub Chat Head icons.
4. Touch a Sub Chat Head to display the log contents.

### Removing a Sub Chat Head Icon

- To remove a sub chat Head icon, press and hold the icon until it disappears.

### Backing Up In Overlay View

RxLogger Utility allows the user to make a zip file of the RxLogger folder in the device, which by default contains all the RxLogger logs stored in the device.

The Backup icon is always available in Overlay View.

1. Touch .  
The Backup dialog box appears.
2. Touch **Yes** to create the backup.



# Data Capture

This section provides information for capturing barcode data using various scanning options.



**NOTE:** Not available on all configurations.

The device supports data capture using:

- Integrated Digital Camera
- Integrated SE965 Standard Range Laser
- Integrated SE4850 Extended Range Imager
- Integrated SE4770-Standard Range Imager
- Integrated SE4750-MR, SE4750-DP, and SE4750-DPW Imagers
- Optional RS507 Hands-Free Imager
- RS5100 Bluetooth Ring Scanner
- RS6000 Hands-free Imager
- DS2278 Digital Scanner
- DS3678 Digital Scanner
- LI3678 Linear Scanner
- DS8178 Digital Scanner



**NOTE:** By default, the good decode beep is set to system volume (Notifications). The good decode beep can be set to another sound (Ringer, Music and Media or Alarms) and the volume can be independently controlled. See [DataWedge](#) on page 97 for more information.

## Status LED

The Charging/Scan LED (1) indicates data capture status. The LED lights green when a barcode is successfully decoded.

**Figure 5** Charging/Scan LED

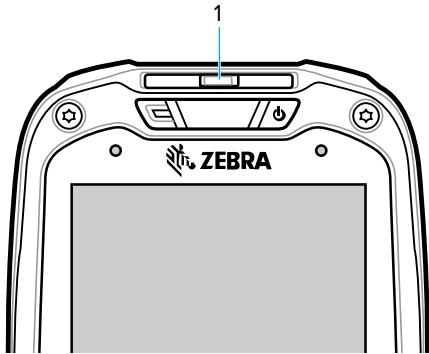

## Laser Scanning

The device with laser scanner has the following features:

- Reading of a variety of barcode symbologies, including the most popular linear, postal, and 1-D code types.
- Intuitive aiming for easy point-and-shoot operation.

## Imaging

The device with an integrated 2D imager has the following features:

- Omnidirectional reading of a variety of barcode symbologies, including the most popular linear, postal, PDF417, Digimarc, and 2D matrix code types.
- The ability to capture and download images to a host for a variety of imaging applications.
- Advanced intuitive laser aiming cross-hair and dot aiming for easy point-and-shoot operation.

The imager uses imaging technology to take a picture of a barcode, stores the resulting image in memory, and executes state-of-the-art software decoding algorithms to extract the barcode data from the image.

## Operational Modes

The device with an integrated imager supports two modes of operation, listed below. Activate each mode pressing the Scan button.

- Decode mode — The device attempts to locate and decode enabled barcodes within its field of view. The imager remains in this mode as long as you hold the scan button, or until it decodes a barcode.
- Pick List mode — Selectively decode a barcode when more than one barcode is in the device's field of view by moving the aiming crosshair or dot over the required barcode. Use this feature for pick lists containing multiple barcodes and manufacturing or transport labels containing more than one barcode type (either 1D or 2D).



**NOTE:** To enable Pick List Mode, configure in DataWedge or set in an application using a API command.

## Digital Camera

The device with an integrated camera based barcode scanning solution has the following features:

- Omnidirectional reading of a variety of barcode symbologies, including the most popular linear, postal, QR, PDF417, and 2D matrix code types.
- Cross-hair reticle for easy point-and-shoot operation.
- Picklist mode to decode a particular barcode from many in the field of view.

The solution uses the advanced camera technology to take a digital picture of a barcode, and executes state-of-the-art software decoding algorithms to extract the data from the image.

## Scanning Considerations

Typically, scanning is a simple matter of aim, scan, and decode, with a few quick trial efforts to master it.

However, consider the following to optimize scanning performance:

- Range — Scanners decode best over a particular working range — minimum and maximum distances from the barcode. This range varies according to barcode density and scanning device optics. Scan within range for quick and constant decodes; scanning too close or too far away prevents decodes. Move the scanner closer and further away to find the right working range for the barcodes being scanned.
- Angle — Scanning angle is important for quick decodes. When the illumination/flash reflects directly back into the imager, the specular reflection can blind/saturate the imager. To avoid this, scan the barcode so that the beam does not bounce directly back. Do not scan at too sharp an angle; the scanner needs to collect scattered reflections from the scan to make a successful decode. Practice quickly shows what tolerances to work within.
- Hold the device farther away for larger symbols.
- Move the device closer for symbols with bars that are close together.



**NOTE:** Scanning procedures depend on the app and device configuration. An app may use different scanning procedures from the one listed above.

## Scanning with the Camera

Use the internal camera to capture barcode data.



**NOTE:** To read a barcode, a scan-enabled app is required. The device contains the DataWedge app that allows the user to enable the scanner to decode barcode data and display the barcode content.

1. Launch a scanning application.

2. Point the camera window at a barcode.

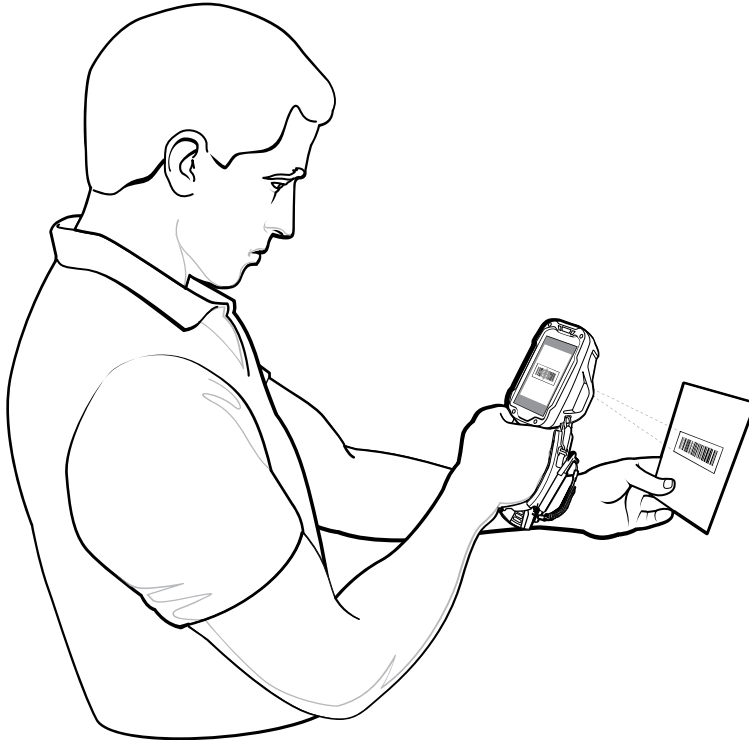

**NOTE:** When Picklist mode is enabled, move the device until the barcode is centered under the red target on the screen.

3. Press and hold the trigger. By default, a preview window appears on the screen.
4. Move the device until the barcode is visible on the screen.
5. The Decode LED lights green, a beep sounds and the device vibrates, by default, to indicate the barcode is decoded successfully.
6. The captured data appears in the text field.
7. Release the trigger.

## Scanning with the Internal Laser Scanner

Use the internal laser scanner to capture barcode data.



**NOTE:** To read a barcode, a scan-enabled app is required. The device contains the DataWedge app that allows the user to enable the scanner to decode barcode data and display the barcode content.

1. Ensure that an application is open on the device and a text field is in focus (text cursor in text field).

2. Point the scan exit window at a barcode.

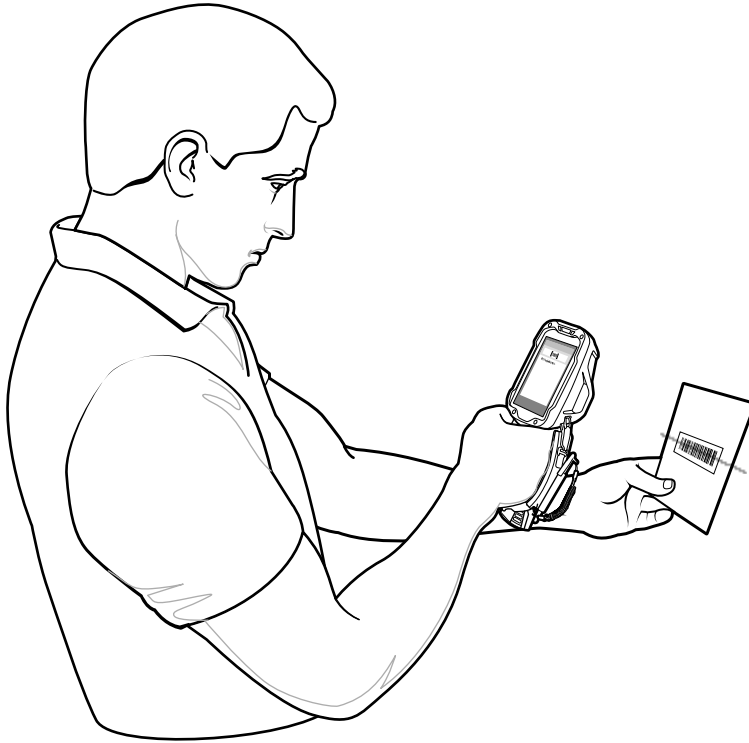

3. Press the trigger button.

Ensure the red scan beam covers the entire barcode. The Charging/Scan LED Indicators illuminate green and a beep sounds to indicate a successful decode.



4. Release the scan button.

The captured data appears in the text field.

## Scanning with the Internal Imager

Use the internal imager to capture barcode data.



**NOTE:** To read a barcode, a scan-enabled app is required. The device contains the DataWedge app that allows the user to enable the scanner to decode barcode data and display the barcode content.

1. Ensure that an application is open on the device and a text field is in focus (text cursor in text field).

2. Point the exit window of the device at a barcode.

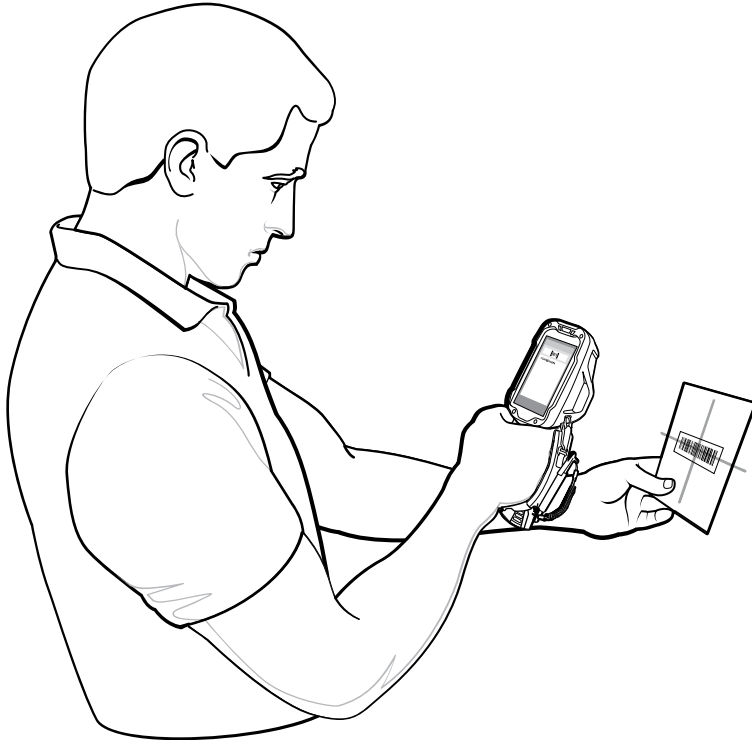

3. Press the trigger button.

4. Ensure the barcode is within the area formed by the aiming pattern. The aiming dot is used for increased visibility in bright lighting conditions.

**Figure 6** Aiming Pattern



**Figure 7** Aiming Pattern - Extended Range

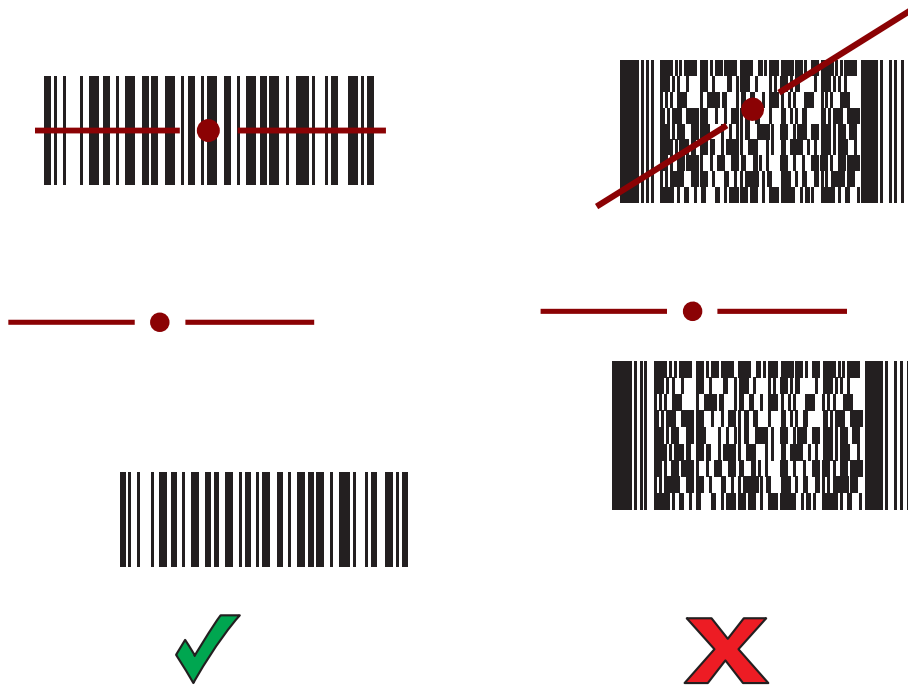



**NOTE:** When the device is in Pick List Mode, the device does not decode the barcode until the center of the crosshair touches the barcode.

**Figure 8** Pick List Mode with Multiple Barcodes - Standard Range



**Figure 9** Pick List Mode with Multiple Barcodes - Extended Range



The Data Capture LED light green and a beep sounds, by default, to indicate the barcode is decoded successfully.

5. Release the trigger.

The barcode content data appears in the text field.



## Scanning with the RS5100 Ring Scanner

Use the RS5100 Ring Scanner to capture barcode data.

**Figure 10** RS5100 Ring Scanner

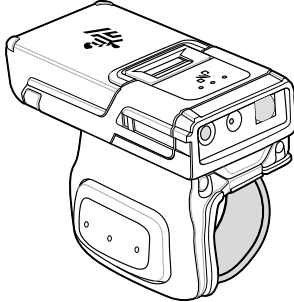

Refer to the RS5100 Ring Scanner Product Reference Guide for more information.



**NOTE:** To read a barcode, a scan-enabled app is required. The device contains the DataWedge app that allows the user to enable the scanner to decode barcode data and display the barcode content.

To scan with the RS5100:

1. Pair the RS5100 with the device.
2. Ensure that an app is open on the device and a text field is in focus (text cursor in text field).
3. Point the RS5100 at a barcode.

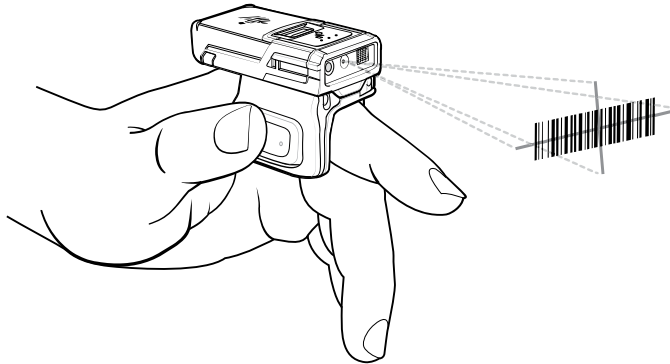

4. Press and hold the trigger.

The red laser aiming pattern turns on to assist in aiming. Ensure the barcode is within the area formed by the cross-hairs in the aiming pattern. The aiming dot increases visibility in bright lighting conditions.

**Figure 11** RS5100 Aiming Pattern

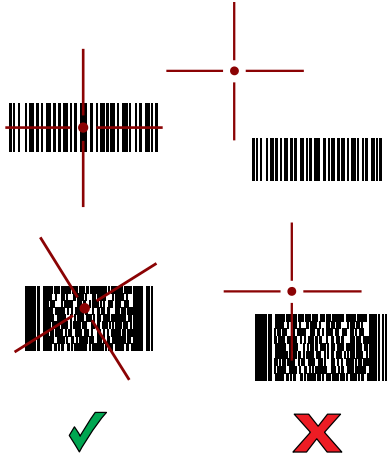

When the RS5100 is in Pick List mode, the RS5100 does not decode the barcode until the center of the crosshair touches the barcode.

**Figure 12** RS5100 Pick List Mode with Multiple Barcodes in Aiming Pattern



The RS5100 LEDs light green and a beep sounds to indicate the barcode was decoded successfully. The captured data appears in the text field.

## Scanning with the RS6000 Bluetooth Ring Scanner

Use the RS6000 Bluetooth Ring Scanner to capture barcode data.

**Figure 13** RS6000 Bluetooth Ring Scanner

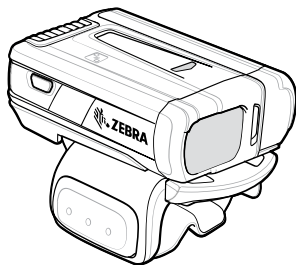

Refer to the RS6000 Bluetooth Ring Scanner Product Reference Guide for more information.



**NOTE:** To read a barcode, a scan-enabled app is required. The device contains the DataWedge app that allows the user to enable the scanner to decode barcode data and display the barcode content.

To scan with the RS6000:

1. Pair the RS6000 with the device.
2. Ensure that an app is open on the device and a text field is in focus (text cursor in text field).
3. Point the RS6000 at a barcode.

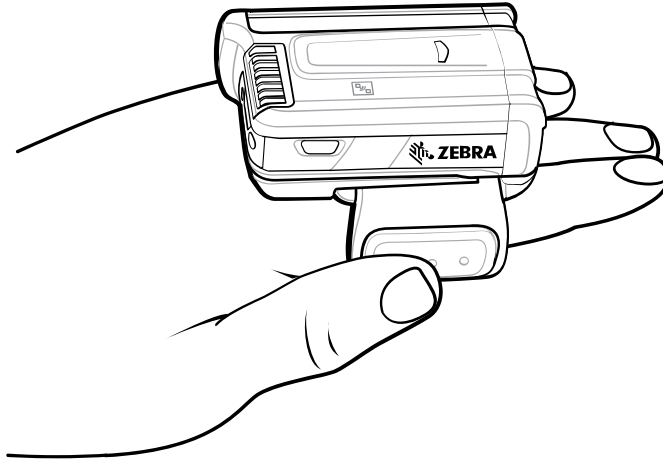

**4.** Press and hold the trigger.

The red laser aiming pattern turns on to assist in aiming. Ensure the barcode is within the area formed by the cross-hairs in the aiming pattern. The aiming dot increases visibility in bright lighting conditions.

**Figure 14** RS6000 Aiming Pattern

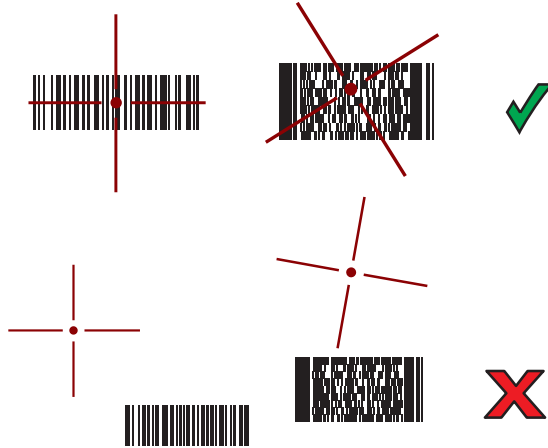

When the RS6000 is in Pick List mode, the RS6000 does not decode the barcode until the center of the crosshair touches the barcode.

**Figure 15** RS6000 Pick List Mode with Multiple Barcodes in Aiming Pattern



The RS6000 LEDs light green and a beep sounds to indicate the barcode was decoded successfully. The captured data appears in the text field.

## Scanning with the DS2278 Digital Scanner

Use the DS2278 Digital Scanner to capture barcode data.

**Figure 16** DS2278 Digital Scanner



Refer to the DS2278 Digital Scanner Product Reference Guide for more information.



**NOTE:** To read a barcode, a scan-enabled app is required. The device contains the DataWedge app that allows the user to enable the scanner to decode barcode data and display the barcode content.

To scan with the DS2278:

1. Pair the DS2278 with the device. See [Pairing a Bluetooth Scanner](#) for more information.
2. Ensure that an app is open on the device and a text field is in focus (text cursor in text field).
3. Point the scanner at a barcode.

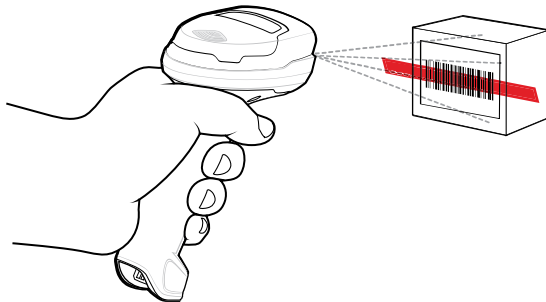

4. Press and hold the trigger.

5. Ensure the aiming pattern covers the barcode.



6. Upon successful decode, the scanner beeps and the LED flashes, and the scan line turns off. The captured data appears in the text field.

## Scanning with the DS3678 Bluetooth Scanner

Use the DS3678 Bluetooth Scanner to capture barcode data.

**Figure 17** DS3678 Digital Scanner

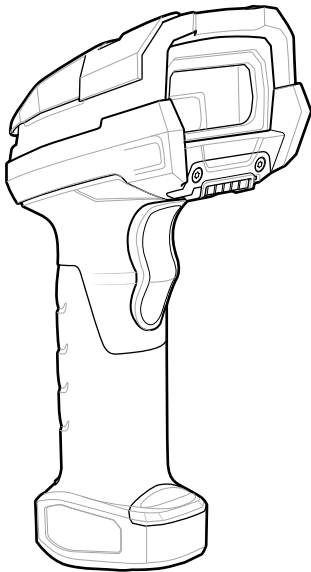

Refer to the DS3678 Product Reference Guide for more information.



**NOTE:** To read a barcode, a scan-enabled app is required. The device contains the DataWedge app that allows the user to enable the scanner to decode barcode data and display the barcode content.

To scan with the DS3678 scanner:

1. Pair the scanner with the device. See [Pairing Bluetooth Scanners](#) for more information.
2. Ensure that an app is open on the device and a text field is in focus (text cursor in text field).

3. Point the scanner at a barcode.

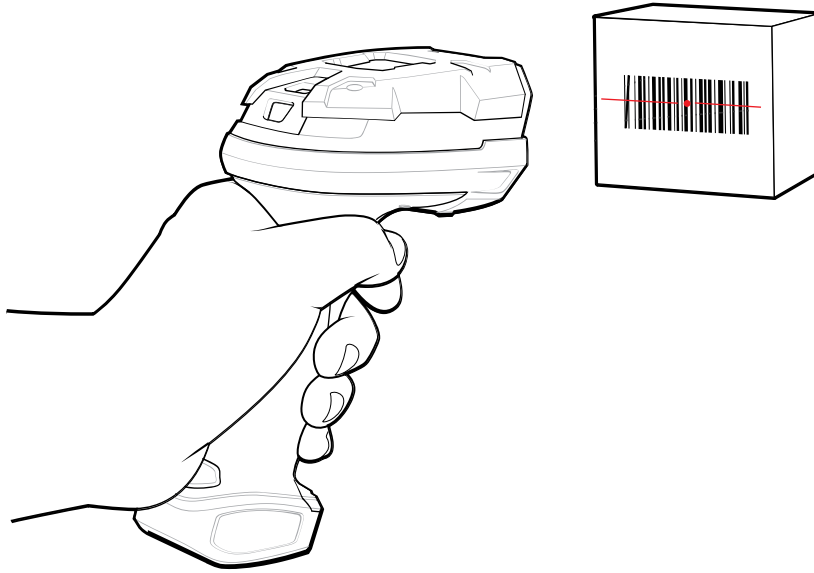

4. Press and hold the trigger.

Ensure the barcode is within the area formed by the aiming pattern. The aiming dot increases visibility in bright lighting conditions.

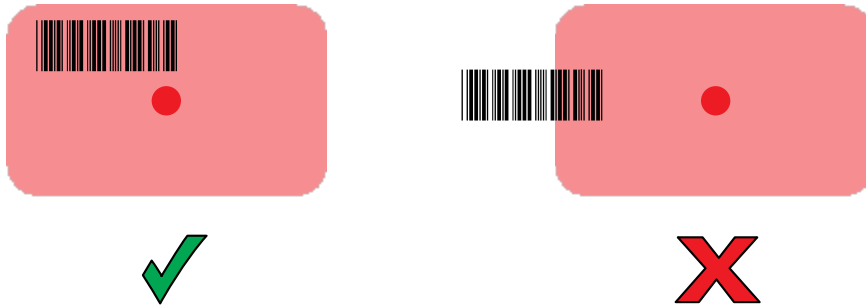

The captured data appears in the text field.

## Scanning with the LI3678 Linear Imager

Use the LI3678 linear imager to capture barcode data.

**Figure 18** LI3678 Bluetooth Scanner

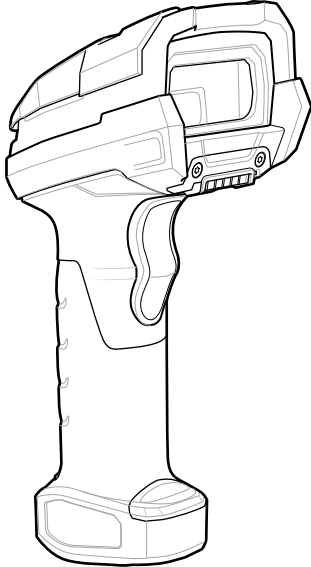

Refer to the LI3678 Product Reference Guide for more information.



**NOTE:** To read a barcode, a scan-enabled app is required. The device contains the DataWedge app that allows the user to enable the scanner to decode barcode data and display the barcode content.

To scan with the LI3678:

1. Pair the LI3678 with the device. See [Pairing a Bluetooth Scanner](#) for more information.
2. Ensure that an app is open on the device and a text field is in focus (text cursor in text field).
3. Point the LI3678 at a barcode.
4. Press and hold the trigger.

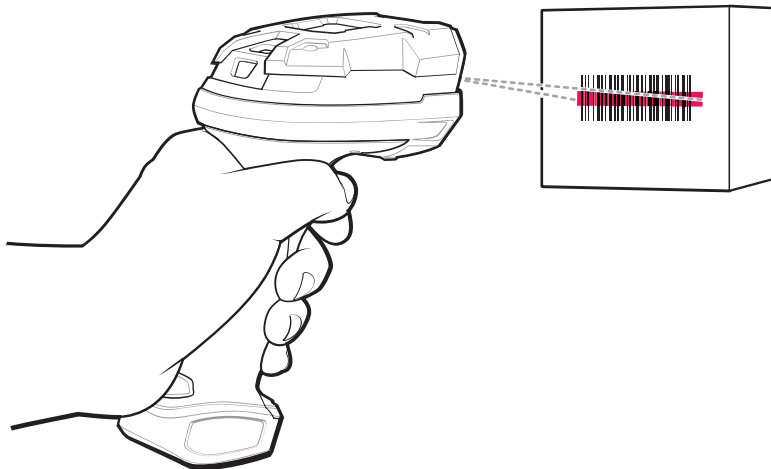



5. Ensure the aiming pattern covers the barcode.

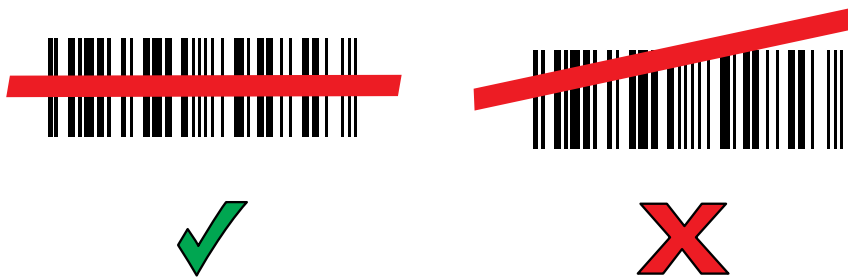

Upon successful decode, the scanner beeps and the LED displays a single green flash.  
The captured data appears in the text field.

## Scanning with the DS8178 Digital Scanner

Use the DS8178 Bluetooth Scanner to capture barcode data.

**Figure 19** DS8178 Digital Scanner

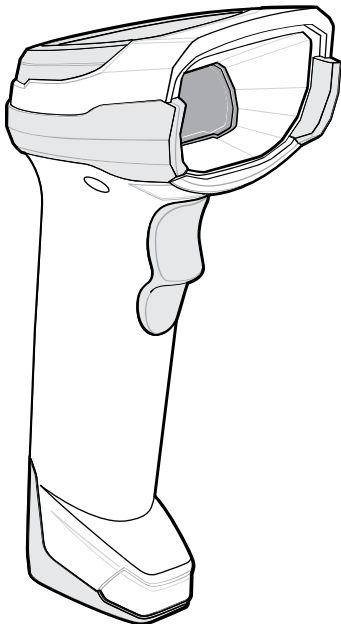

Refer to the DS8178 Digital Scanner Product Reference Guide for more information.



**NOTE:** To read a barcode, a scan-enabled app is required. The device contains the DataWedge app that allows the user to enable the scanner to decode barcode data and display the barcode content.

To scan with the DS8178 scanner:

1. Pair the scanner with the device. See [Pairing Bluetooth Scanners](#) for more information.
2. Ensure that an app is open on the device and a text field is in focus (text cursor in text field).

3. Point the scanner at a barcode.

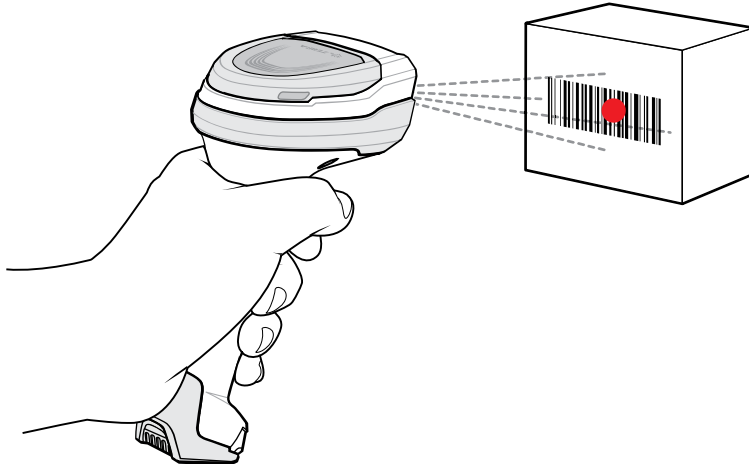

4. Press and hold the trigger.
5. Ensure the barcode is within the area formed by the aiming pattern. The aiming dot increases visibility in bright lighting conditions.

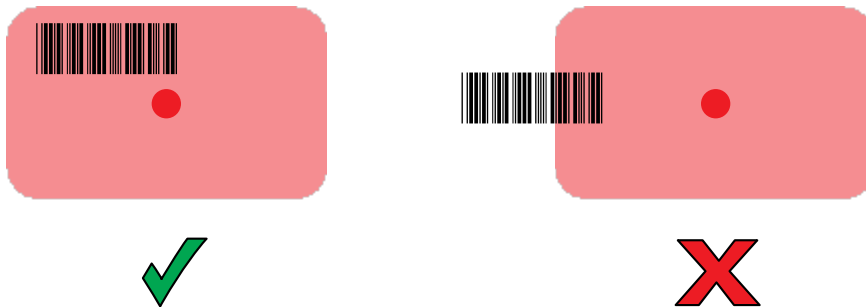

6. Upon successful decode, the scanner beeps and the LED flashes, and the scan line turns off. The captured data appears in the text field.

## Pairing a Bluetooth Scanner

Before using a Bluetooth scanner with the device, connect the device to the Bluetooth scanner.

Connect the scanner to the device using one of the following methods:

- Simple Serial Interface (SSI) mode
- Bluetooth Human Interface Device (HID) mode.

### Pairing Using Simple Serial Interface

An RS507 Hands-free Imager can be used with the device to capture barcode data.

1. Ensure that the two devices are within 10 meters (32.8 feet) of one another.
2. Swipe up from the bottom of the Home screen and touch .

3. Swipe up from the bottom of the Home screen and touch .



4. Using the RS507, scan the barcode on the screen.

The RS507 emits a high/low/high/low beeps. The Scan LED flashes green indicating that the RS507 is attempting to establish connection with the device. When connection is established, the Scan LED turns off and the RS507 emits one string of low/high beeps.

### Pairing Using Bluetooth Human Interface Device

An RS507 Hands-free Imager can be used with the device to capture barcode data.

1. Ensure that Bluetooth is enabled on both devices.
2. Ensure that the Bluetooth device to discover is in discoverable mode.
3. Ensure that the two devices are within 10 meters (32.8 feet) of one another.

4. Place the RS507 in HID mode. If the Ring Scanner is already in HID mode, skip to step 5.
  - a) Remove the battery from the RS507.
  - b) Press and hold the Restore key.
  - c) Install the battery onto the RS507.
  - d) Keep holding the Restore key for about five seconds until a chirp is heard and the Scan LEDs flash green.
  - e) Scan the barcode below to place the RS507 in HID mode.

**Figure 20** RS507 Bluetooth HID Barcode

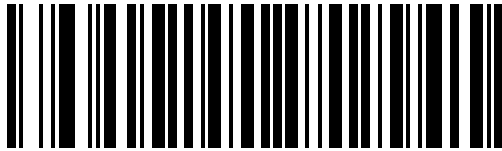

5. Remove the battery from the RS507.
6. Re-install the battery into the RS507.
7. Swipe down from the Status bar to open the Quick Access panel and then touch .
8. Touch **Bluetooth**.
9. Touch **Pair new device**. The device begins searching for discoverable Bluetooth devices in the area and displays them under **Available devices**.
10. Scroll through the list and select RS507.

The device connects to the RS507 and **Connected** appears below the device name. The Bluetooth device is added to the **Paired devices** list and a trusted (“paired”) connection is established.

A notification appears on the Notification panel and the  icon appears in the Status bar.

## Hands Free Scanning

Hands Free Scanning allows the user to capture barcode data when a barcode is placed within the view of the device without pressing the trigger.



**NOTE:** The Hands Free Scanning is only available on devices with the imager engine.

Hands Free Scanning is enabled using the Hands Free Scanning settings or when the device is placed in the Presentation Holster or the Desk Stand. Hands Free Scanning is set to disabled by default.

**Figure 21** Scanning in Presentation Holster



**Figure 22** Scanning in Desk Stand

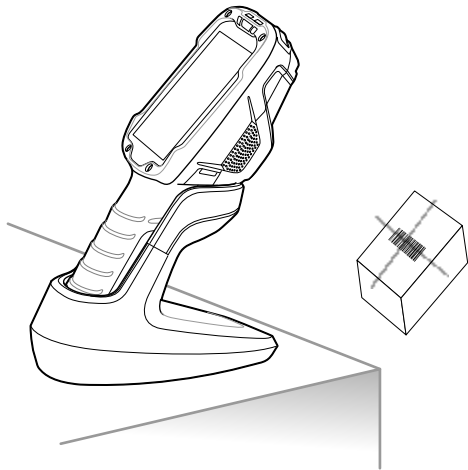

**Figure 23** Scanning in Cart Mount

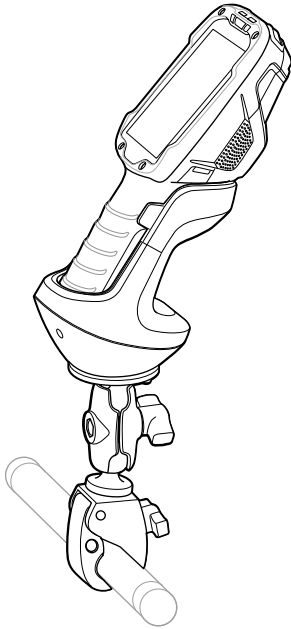

## Hands Free Scanning Settings

Use the **Hands Free Scanning** setting to configure scanning mode and the proximity trigger sensitivity. Swipe up from the bottom of the Home screen and touch **Setting** > **Hands Free Scanning**.

**Figure 24** Hands Free Scanning Settings

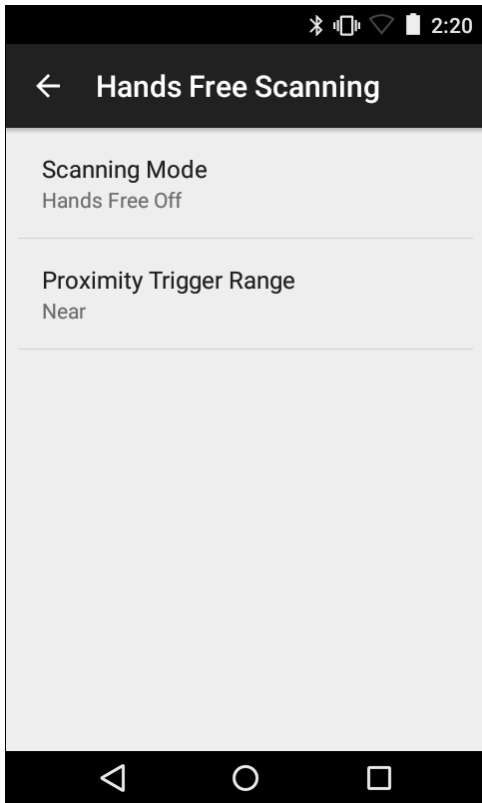

## Scanning Mode

Use the **Scanning Mode** settings to configure how the device functions while in hands-free scanning mode.

**Figure 25** Scanning Mode Dialog Box

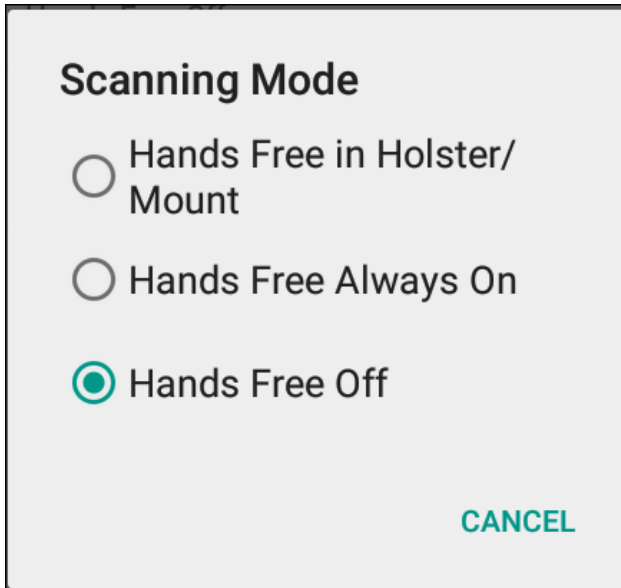

The dialog box is titled "Scanning Mode" and contains three radio button options. The first option is "Hands Free in Holster/ Mount", the second is "Hands Free Always On", and the third is "Hands Free Off", which is selected. A "CANCEL" button is located at the bottom right of the dialog box.

- **Hands Free in Cart/Mount** - Select to enable scanning when the device is in the Presentation Holster, Desk Stand or Cart Mount.
- **Hands Free Always On** - Select to place the device in hands free scanning mode.
- **Hands Free Off** - Select to disable hands free scanning mode (default).

## Proximity Range

To configure the proximity sensor range sensitivity, touch **Proximity Trigger Range**.

**Figure 26** Proximity Trigger Range Dialog Box

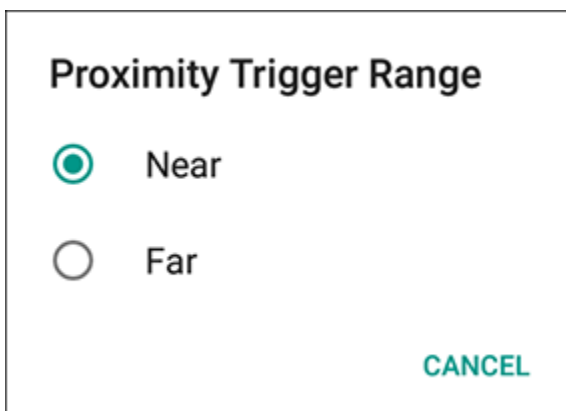

The dialog box is titled "Proximity Trigger Range" and contains two radio button options. The first option is "Near", which is selected, and the second is "Far". A "CANCEL" button is located at the bottom right of the dialog box.

- **Near** — Proximity sensor detects and generates a trigger when the barcode is within 0 to 15 cm (nominal) (default). Ideally, 0-5 in (approx. 13 cm) is supported.



- **Far** — Proximity sensor detects and generates a trigger when the barcode is within 0 to 26 cm (nominal). The maximum range is 10 in (approx. 26 cm).

## DataWedge

DataWedge is a utility that adds advanced barcode scanning capability to any application without writing code. It runs in the background and handles the interface to built-in barcode scanners. The captured barcode data is converted to keystrokes and sent to the target application as if it was typed on the keypad.

DataWedge allows any app on the device to get data from input sources such as a barcode scanner, MSR, RFID, voice, or serial port and manipulate the data based on options or rules.



Configure DataWedge to:

- Provide data capture services from any app.
- Use a particular scanner, reader, or other peripheral devices.
- Properly format and transmit data to a specific app.

To configure DataWedge, refer to [techdocs.zebra.com/datawedge/](http://techdocs.zebra.com/datawedge/).

## Enabling DataWedge



This procedure provides information on how to enable DataWedge on the device.

1. Swipe up from the bottom of the Home screen and touch .
2. Touch  > **Settings**.
3. Touch the **DataWedge enabled** checkbox.

A blue checkmark appears in the checkbox indicating that DataWedge is enabled.

## Disabling DataWedge

This procedure provides information on how to disable DataWedge on the device.

1. Swipe up from the bottom of the Home screen and touch .
2. Touch .
3. Touch **Settings**.
4. Touch **DataWedge enabled**.

## Supported Devices

This sections provides the supported decoders for each data capture option.

### Camera Supported Decoders

Lists the supported decoders for the internal camera.

**Table 10** Camera Supported Decoders

Decoder	Default State	Decoder	Default State	Decoder	Default State
Australian Postal	O	EAN8	X	MSI	O
Aztec	X	Grid Matrix	O	PDF417	X
Canadian Postal	O	GS1 DataBar	X	QR Code	X
Chinese 2 of 5	O	GS1 DataBar Expanded	X	Decoder Signature	O
Codabar	X	GS1 DataBar Limited	O	TLC 39	O
Code 11	O	GS1 Datamatrix	O	Trioptic 39	O
Code 128	X	GS1 QRCode	O	UK Postal	O
Code 39	X	HAN XIN	O	UPCA	X
Code 93	O	Interleaved 2 of 5	O	UPCE0	X
Composite AB	O	Japanese Postal	O	UPCE1	O
Composite C	O	Korean 3 of 5	O	US4state	O
Discrete 2 of 5	O	MAIL MARK	X	US4state FICS	O
Datamatrix	X	Matrix 2 of 5	O	US Planet	O
Dutch Postal	O	Maxicode	X	US Postnet	O
DotCode	X	MicroPDF	O		
EAN13	X	MicroQR	O		

Key: X = Enabled, O = Disabled, - = Not Supported

### SE965 Internal Laser Scanner Supported Decoders

Lists the supported decoders for the internal SE965 laser scanner.

**Table 11** Internal SE965 Laser Scanner Supported Decoders

Decoder	Default State	Decoder	Default State	Decoder	Default State
Australian Postal	—	EAN8	# X #	MSI	O

**Table 11** Internal SE965 Laser Scanner Supported Decoders (Continued)

Decoder	Default State	Decoder	Default State	Decoder	Default State
Aztec	—	Grid Matrix	O	PDF417	—
Canadian Postal	—	GS1 DataBar	X	QR Code	—
Chinese 2 of 5	O	GS1 DataBar Expanded	X	Decoder Signature	—
Codabar	X	GS1 DataBar Limited	O	TLC 39	O
Code 11	O	GS1 Datamatrix	—	Trioptic 39	O
Code 128	X	GS1 QRCode	—	UK Postal	—
Code 39	X	HAN XIN	—	UPCA	X
Code 93	O	Interleaved 2 of 5	O	UPCE0	X
Composite AB	—	Japanese Postal	—	UPCE1	O
Composite C	—	Korean 3 of 5	O	US4state	—
Discrete 2 of 5	O	MAIL MARK	—	US4state FICS	—
Datamatrix	—	Matrix 2 of 5	O	US Planet	—
Dutch Postal	—	Maxicode	—	US Postnet	—
DotCode	O	MicroPDF	—		
EAN13	X	MicroQR	—		

Key: X = Enabled, O = Disabled, - = Not Supported

## SE4850-ER, SE4770-SR, SE4750-MR Internal Imager Supported Decoders

Lists the supported decoders for the SE4850-ER, SE4770-SR, and SE4750-MR internal imager.

**Table 12** SE4850-ER, SE4770-SR, and SE4750-MR Internal Imager Supported Decoders

Decoder	Default State	Decoder	Default State	Decoder	Default State
Australian Postal	O	EAN8	X	MSI	O
Aztec	X	Grid Matrix	O	PDF417	X
Canadian Postal	O	GS1 DataBar	X	QR Code	X
Chinese 2 of 5	O	GS1 DataBar Expanded	X	Decoder Signature	O
Codabar	X	GS1 DataBar Limited	O	TLC 39	O
Code 11	O	GS1 Datamatrix	O	Trioptic 39	O

**Table 12** SE4850-ER, SE4770-SR, and SE4750-MR Internal Imager Supported Decoders (Continued)

Decoder	Default State	Decoder	Default State	Decoder	Default State
Code 128	X	GS1 QRCode	O	UK Postal	O
Code 39	X	HAN XIN	O	UPCA	X
Code 93	O	Interleaved 2 of 5	O	UPCE0	X
Composite AB	O	Japanese Postal	O	UPCE1	O
Composite C	O	Korean 3 of 5	O	US4state	O
Discrete 2 of 5	O	MAIL MARK	X	US4state FICS	O
Datamatrix	X	Matrix 2 of 5	O	US Planet	O
Dutch Postal	O	Maxicode	X	US Postnet	O
DotCode	O	MicroPDF	O		
EAN13	X	MicroQR	O		

Key: X = Enabled, O = Disabled, - = Not Supported

## SE4750-DP and SE4750-DPA Internal Imager Supported Decoders

Lists the supported decoders for the SE4750-DP and SE4750-DPA internal imager.

**Table 13** SE4750-DP and SE4750-DPA Internal Imager Supported Decoders

Decoder	Default State	Decoder	Default State	Decoder	Default State
Australian Postal	O	EAN8	X	MSI	O
Aztec	X	Grid Matrix	O	PDF417	X
Canadian Postal	O	GS1 DataBar	X	QR Code	X
Chinese 2 of 5	O	GS1 DataBar Expanded	X	Decoder Signature	O
Codabar	X	GS1 DataBar Limited	O	TLC 39	O
Code 11	O	GS1 Datamatrix	O	Trioptic 39	O
Code 128	X	GS1 QRCode	O	UK Postal	O
Code 39	X	HAN XIN	O	UPCA	X
Code 93	O	Interleaved 2 of 5	O	UPCE0	X
Composite AB	O	Japanese Postal	O	UPCE1	O
Composite C	O	Korean 3 of 5	O	US4state	O
Discrete 2 of 5	O	MAIL MARK	X	US4state FICS	O

**Table 13** SE4750-DP and SE4750-DPA Internal Imager Supported Decoders (Continued)

Decoder	Default State	Decoder	Default State	Decoder	Default State
Datamatrix	X	Matrix 2 of 5	O	US Planet	O
Dutch Postal	O	Maxicode	X	US Postnet	O
DotCode	O	MicroPDF	O		
EAN13	X	MicroQR	O		

Key: X = Enabled, O = Disabled, - = Not Supported

## RS5100 Supported Decoders

Lists the supported decoders for the RS5100 Ring Scanner.

**Table 14** RS5100 Supported Decoders

Decoder	Default State	Decoder	Default State	Decoder	Default State
Australian Postal	O	EAN8	X	MSI	O
Aztec	X	Grid Matrix	O	PDF417	X
Canadian Postal	O	GS1 DataBar	X	QR Code	X
Chinese 2 of 5	O	GS1 DataBar Expanded	X	Decoder Signature	O
Codabar	X	GS1 DataBar Limited	O	TLC 39	O
Code 11	O	GS1 Datamatrix	O	Trioptic 39	O
Code 128	X	GS1 QRCode	O	UK Postal	O
Code 39	X	HAN XIN	O	UPCA	X
Code 93	O	Interleaved 2 of 5	O	UPCE0	X
Composite AB	O	Japanese Postal	O	UPCE1	O
Composite C	O	Korean 3 of 5	O	US4state	O
Discrete 2 of 5	O	MAIL MARK	X	US4state FICS	O
Datamatrix	X	Matrix 2 of 5	O	US Planet	O
Dutch Postal	O	Maxicode	X	US Postnet	O
DotCode	O	MicroPDF	O		
EAN13	X	MicroQR	O		

Key: X = Enabled, O = Disabled, - = Not Supported

## RS6000 Supported Decoders

Lists the supported decoders for the RS6000 Ring Scanner.

**Table 15** RS6000 Supported Decoders

Decoder	Default State	Decoder	Default State	Decoder	Default State
Australian Postal	O	EAN8	X	MSI	O
Aztec	X	Grid Matrix	O	PDF417	X
Canadian Postal	O	GS1 DataBar	X	QR Code	X
Chinese 2 of 5	O	GS1 DataBar Expanded	X	Decoder Signature	O
Codabar	X	GS1 DataBar Limited	O	TLC 39	O
Code 11	O	GS1 Datamatrix	O	Trioptic 39	O
Code 128	X	GS1 QRCode	O	UK Postal	O
Code 39	X	HAN XIN	O	UPCA	X
Code 93	O	Interleaved 2 of 5	O	UPCE0	X
Composite AB	O	Japanese Postal	O	UPCE1	O
Composite C	O	Korean 3 of 5	O	US4state	O
Discrete 2 of 5	O	MAIL MARK	X	US4state FICS	O
Datamatrix	X	Matrix 2 of 5	O	US Planet	O
Dutch Postal	O	Maxicode	X	US Postnet	O
DotCode	O	MicroPDF	O		
EAN13	X	MicroQR	O		

Key: X = Enabled, O = Disabled, - = Not Supported

## DS2278 Supported Decoders

Lists the supported decoders for the DS2278 Digital Scanner.

**Table 16** DS2278 Digital Scanner Supported Decoders

Decoder	Default State	Decoder	Default State	Decoder	Default State
Australian Postal	O	EAN8	X	MSI	O
Aztec	X	Grid Matrix	O	PDF417	X
Canadian Postal	—	GS1 DataBar	X	QR Code	X

**Table 16** DS2278 Digital Scanner Supported Decoders (Continued)

Decoder	Default State	Decoder	Default State	Decoder	Default State
Chinese 2 of 5	O	GS1 DataBar Expanded	X	Decoder Signature	O
Codabar	X	GS1 DataBar Limited	O	TLC 39	O
Code 11	O	GS1 Datamatrix	O	Trioptic 39	O
Code 128	X	GS1 QRCode	O	UK Postal	O
Code 39	X	HAN XIN	—	UPCA	X
Code 93	O	Interleaved 2 of 5	O	UPCE0	X
Composite AB	O	Japanese Postal	O	UPCE1	O
Composite C	O	Korean 3 of 5	O	US4state	O
Discrete 2 of 5	O	MAIL MARK	X	US4state FICS	O
Datamatrix	X	Matrix 2 of 5	O	US Planet	O
Dutch Postal	O	Maxicode	X	US Postnet	O
DotCode	O	MicroPDF	O		
EAN13	X	MicroQR	O		

Key: X = Enabled, O = Disabled, — = Not Supported

## DS3678 Supported Decoders

Lists the supported decoders for the DS3678 scanner.

**Table 17** DS3678 Supported Decoders

Decoder	Default State	Decoder	Default State	Decoder	Default State
Australian Postal	O	EAN8	X	MSI	O
Aztec	X	Grid Matrix	O	PDF417	X
Canadian Postal	—	GS1 DataBar	X	QR Code	X
Chinese 2 of 5	O	GS1 DataBar Expanded	X	Decoder Signature	—
Codabar	X	GS1 DataBar Limited	O	TLC 39	O
Code 11	O	GS1 Datamatrix	O	Trioptic 39	O
Code 128	X	GS1 QRCode	O	UK Postal	O
Code 39	X	HAN XIN	O	UPCA	X

**Table 17** DS3678 Supported Decoders (Continued)

Decoder	Default State	Decoder	Default State	Decoder	Default State
Code 93	O	Interleaved 2 of 5	O	UPCE0	X
Composite AB	O	Japanese Postal	O	UPCE1	O
Composite C	O	Korean 3 of 5	O	US4state	O
Discrete 2 of 5	O	MAIL MARK	X	US4state FICS	O
Datamatrix	X	Matrix 2 of 5	O	US Planet	O
Dutch Postal	O	Maxicode	X	US Postnet	O
DotCode	O	MicroPDF	O		
EAN13	X	MicroQR	O		

Key: X = Enabled, O = Disabled, — = Not Supported

## LI3678 Supported Decoders

Lists the supported decoders for the LI3678 scanner.

**Table 18** LI3678 Supported Decoders

Decoder	Default State	Decoder	Default State	Decoder	Default State
Australian Postal	—	EAN8	X	MSI	O
Aztec	—	Grid Matrix	O	PDF417	—
Canadian Postal	—	GS1 DataBar	X	QR Code	—
Chinese 2 of 5	O	GS1 DataBar Expanded	X	Decoder Signature	—
Codabar	X	GS1 DataBar Limited	O	TLC 39	O
Code 11	O	GS1 Datamatrix	—	Trioptic 39	O
Code 128	X	GS1 QRCode	—	UK Postal	—
Code 39	X	HAN XIN	O	UPCA	X
Code 93	O	Interleaved 2 of 5	O	UPCE0	X
Composite AB	—	Japanese Postal	—	UPCE1	O
Composite C	—	Korean 3 of 5	O	US4state	—
Discrete 2 of 5	O	MAIL MARK	—	US4state FICS	—
Datamatrix	—	Matrix 2 of 5	O	US Planet	—
Dutch Postal	—	Maxicode	—	US Postnet	—



**Table 18** LI3678 Supported Decoders (Continued)

Decoder	Default State	Decoder	Default State	Decoder	Default State
DotCode	O	MicroPDF	—		
EAN13	X	MicroQR	—		

Key: X = Enabled, O = Disabled, — = Not Supported

## DS8178 Supported Decoders

Lists the supported decoders for the DS8178 Digital scanner.

**Table 19** DS8178 Digital Scanner Supported Decoders

Decoder	Default State	Decoder	Default State	Decoder	Default State
Australian Postal	O	EAN8	X	MSI	O
Aztec	X	Grid Matrix	O	PDF417	X
Canadian Postal	—	GS1 DataBar	X	QR Code	X
Chinese 2 of 5	O	GS1 DataBar Expanded	X	Decoder Signature	—
Codabar	X	GS1 DataBar Limited	O	TLC 39	O
Code 11	O	GS1 Datamatrix	O	Trioptic 39	O
Code 128	X	GS1 QRCode	O	UK Postal	O
Code 39	X	HAN XIN	—	UPCA	X
Code 93	O	Interleaved 2 of 5	O	UPCE0	X
Composite AB	O	Japanese Postal	O	UPCE1	O
Composite C	O	Korean 3 of 5	O	US4state	O
Discrete 2 of 5	O	MAIL MARK	X	US4state FICS	O
Datamatrix	X	Matrix 2 of 5	O	US Planet	O
Dutch Postal	O	Maxicode	X	US Postnet	O
DotCode	O	MicroPDF	O		
EAN13	X	MicroQR	O		

Key: X = Enabled, O = Disabled, — = Not Supported

# Wireless

This section provides information on the wireless features of the device.

The following wireless features are available on the device:

- Wireless Local Area Network (WLAN)
- Bluetooth
- Cast
- Near Field Communications (NFC)

## Wireless Local Area Networks

Wireless local area networks (WLANs) allow the device to communicate wirelessly inside a building. Before using the device on a WLAN, the facility must be set up with the required hardware to run the WLAN (sometimes known as infrastructure). The infrastructure and the device must both be properly configured to enable this communication.

Refer to the documentation provided with the infrastructure (access points (APs), access ports, switches, Radius servers, etc.) for instructions on how to set up the infrastructure.

Once the infrastructure is set up to enforce the chosen WLAN security scheme, use the **Wireless & networks** settings to configure the device to match the security scheme.

The device supports the following WLAN security options:

- None
- Enhanced Open
- Wireless Equivalent Privacy (WEP)
- Wi-Fi Protected Access (WPA)/WPA2 Personal (PSK)
- WPA3-Personal
- WPA/WPA2/WPA3 Enterprise (EAP)
  - Protected Extensible Authentication Protocol (PEAP) - with MSCHAPV2 and GTC authentication.
  - Transport Layer Security (TLS)
  - Tunneled Transport Layer Security (TTLS) - with Password Authentication Protocol (PAP), MSCHAP, MSCHAPv2, and GTC authentication.
  - Password (PWD).
  - Lightweight Extensible Authentication Protocol (LEAP).

- WPA3-Enterprise 192-bit

The **Status** bar displays icons that indicate Wi-Fi network availability and Wi-Fi status.



**NOTE:** To extend the life of the battery, turn off Wi-Fi when not in use.

## Connecting to a Wi-Fi Network

1. Go to **Settings**.
2. Touch **Network & internet**.
3. Touch **Wi-Fi** to open the **Wi-Fi** screen. The device searches for WLANs in the area and lists them.
4. Scroll through the list and select the desired WLAN network.
5. For open networks, touch profile once or press and hold and then select **Connect** or for secure networks enter the required password or other credentials then touch **Connect**. See the system administrator for more information.



The device obtains a network address and other required information from the network using the dynamic host configuration protocol (DHCP) protocol. To configure the device with a fixed internet protocol (IP) address, see [Configuring the Device to Use a Static IP Address](#) on page 110.

6. In the Wi-Fi setting field, **Connected** appears indicating that the device is connected to the WLAN.

## Wi-Fi Version

When the device is connected to a Wi-Fi network, the Wi-Fi icon on the Status bar indicates the Wi-Fi network version.

**Table 20** Wi-Fi Version Icons

Icon	Description
	Connected to Wi-Fi 5, the 802.11ac standard.
	Connected to Wi-Fi 4, the 802.11n standard.

## Removing a Wi-Fi Network

Remove a remembered or connected Wi-Fi network.

1. Go to **Settings**.
2. Touch **Network & Internet > Wi-Fi**.
3. Scroll down to the bottom of the list and touch **Saved networks**.
4. Touch the name of the network.
5. Touch **FORGET**.

## WLAN Configuration

This section provides information on configuring Wi-Fi settings.

### Configuring a Secure Wi-Fi Network

1. Go to **Settings**.
  2. Touch **Network & Internet > Wi-Fi**.
  3. Slide the switch to the **ON** position.
  4. The device searches for WLANs in the area and lists them on the screen.
  5. Scroll through the list and select the desired WLAN network.
  6. Touch the desired network. If network security is **Open**, the device automatically connects to the network. For all other network security, a dialog box appears.
  7. If network security is **WPA/WPA2-Personal**, **WPA3-Personal**, or **WEP**, enter the required password and then touch **Connect**.
  8. If network security is **WPA/WPA2/WPA3 Enterprise**:
    - a) Touch the **EAP method** drop-down list and select one of the following:
      - **PEAP**
      - **TLS**
      - **TTLS**
      - **PWD**
      - **LEAP**
    - b) Fill in the appropriate information. Options vary depending on the **EAP method** chosen.
      - When selecting **CA certificate**, Certification Authority (CA) certificates are installed using the **Security** settings.
      - When using the EAP methods PEAP, TLS, or TTLS, specify a domain.
      - Touch **Advanced options** to display additional network options.
  9. If the network security is **WPA3-Enterprise 192-bit**:
    - Touch **CA certificate** and select a Certification Authority (CA) certificate. Note: Certificates are installed using the Security settings.
    - Touch **User certificate** and select a user certificate. Note: User certificates are installed using the Security settings.
    - In the **Identity** text box, enter the username credentials.
-  **NOTE:** By default, the network Proxy is set to None and the IP settings is set to DHCP. See [Configuring for a Proxy Server](#) on page 110 for setting the connection to a proxy server and see [Configuring the Device to Use a Static IP Address](#) on page 110 for setting the device to use a static IP address.
10. Touch **Connect**.

## Manually Adding a Wi-Fi Network

Manually add a Wi-Fi network if the network does not broadcast its name (SSID) or to add a Wi-Fi network when out of range.

1. Go to **Settings**.
2. Touch **Network & Internet > Wi-Fi**.
3. Slide the Wi-Fi switch to the **On** position.
4. Scroll to the bottom of the list and select **Add network**.
5. In the **Network name** text box, enter the name of the Wi-Fi network.
6. In the **Security** drop-down list, set the type of security to:
  - **None**
  - **Enhanced Open**
  - **WEP**
  - **WPA/WPA2-Personal**
  - **WPA3-Personal**
  - **WPA/WPA2/WPA3-Enterprise**
  - **WPA3-Enterprise 192-bit**
7. If the network security is **None** or **Enhanced Open**, touch **Save**.
8. If the network security is **WEP**, **WPA3-Personal**, or **WPA/WPA2-Personal**, enter the required password and then touch **Save**.
9. If network security is **WPA/WPA2/WPA3 Enterprise**:
  - a) Touch the **EAP method** drop-down list and select one of the following:
    - **PEAP**
    - **TLS**
    - **TTLS**
    - **PWD**
    - **LEAP**
  - b) Fill in the appropriate information. Options vary depending on the **EAP method** chosen.
    - When selecting **CA certificate**, Certification Authority (CA) certificates are installed using the **Security** settings.
    - When using the EAP methods PEAP, TLS, or TTLS, specify a domain.
    - Touch **Advanced options** to display additional network options.
10. If the network security is **WPA3-Enterprise 192-bit**:
  - You must specify a domain and user certificate
  - Certification Authority (CA) and User certificates are installed using the **Security** settings.
  - Touch **Advanced options** to display additional network options.



**NOTE:** By default, the network Proxy is set to None and the IP settings is set to DHCP. See [Configuring for a Proxy Server](#) on page 110 for setting the connection to a proxy server and

see [Configuring the Device to Use a Static IP Address](#) on page 110 for setting the device to use a static IP address.

11. Touch **Save**. To connect to the saved network, touch and hold on the saved network and select **Connect to network**.

## Configuring for a Proxy Server

A proxy server is a server that acts as an intermediary for requests from clients seeking resources from other servers. A client connects to the proxy server and requests some service, such as a file, connection, web page, or other resource, available from a different server. The proxy server evaluates the request according to its filtering rules. For example, it may filter traffic by IP address or protocol. If the request is validated by the filter, the proxy provides the resource by connecting to the relevant server and requesting the service on behalf of the client.

It is important for enterprise customers to be able to set up secure computing environments within their companies, making proxy configuration essential. Proxy configuration acts as a security barrier ensuring that the proxy server monitors all traffic between the Internet and the intranet. This is normally an integral part of security enforcement in corporate firewalls within intranets.

1. Go to **Settings**.
2. Touch **Network & Internet > Wi-Fi**.
3. Slide the Wi-Fi switch to the **On** position.
4. In the network dialog box, select and touch a network.
5. If configuring the connected network, touch  to edit the network details and then touch the down arrow to hide the keyboard.
6. Touch **Advanced options**.
7. Touch **Proxy** and select **Manual**.
8. In the **Proxy hostname** text box, enter the address of the proxy server.
9. In the **Proxy port** text box, enter the port number for the proxy server.
10. In the **Bypass proxy for** text box, enter addresses for web sites that are not required to go through the proxy server. Use a comma “,” between addresses. Do not use spaces or carriage returns between addresses.
11. If configuring the connected network, touch **Save** otherwise, touch **Connect**.
12. Touch **Connect**.

## Configuring the Device to Use a Static IP Address

By default, the device is configured to use Dynamic Host Configuration Protocol (DHCP) to assign an Internet protocol (IP) address when connecting to a wireless network.

1. Go to **Settings**.
2. Touch **Network & Internet > Wi-Fi**.
3. Slide the Wi-Fi switch to the **On** position.
4. In the network dialog box, select and touch a network.
5. If configuring the connected network, touch  to edit the network details and then touch the down arrow to hide the keyboard.

6. Touch **Advanced options**.
7. Touch **IP settings** and select **Static**.
8. In the **IP address** text box, enter an IP address for the device.
9. If required, in the **Gateway** text box, enter a gateway address for the device.
10. If required, in the **Network prefix length** text box, enter the prefix length.
11. If required, in the **DNS 1** text box, enter a Domain Name System (DNS) address.
12. If required, in the **DNS 2** text box, enter a DNS address.
13. If configuring the connected network, touch **Save** otherwise, touch **Connect**.

## Wi-Fi Preferences

Use the Wi-Fi preferences to configure advanced Wi-Fi settings. From the Wi-Fi screen scroll down to the bottom of the screen and touch Wi-Fi preferences.

- **Turn on Wi-Fi automatically** - When enabled, Wi-Fi automatically turns back on when near high-quality saved networks.
- **Open network notification** - When enabled, notifies the user when an open network is available.
- **Advanced** - Touch to expand options.
  - **Additional settings** - Touch to view additional Wi-Fi settings.
  - **Install Certificates** – Touch to install certificates.
  - **Network rating provider** - Disabled (AOSP devices). To help determine what constitutes a good Wi-Fi network, Android supports external Network rating providers that provide information about the quality of open Wi-Fi networks. Select one of the providers listed or **None**. If none are available or selected, the Connect to open networks feature is disabled.
  - **Wi-Fi Direct** - Displays a list of devices available for a direct Wi-Fi connection.

## Additional Wi-Fi Settings

Use the Additional Settings to configure additional Wi-Fi settings. To view the additional Wi-Fi settings, scroll to the bottom of the Wi-Fi screen and touch **Wi-Fi Preferences > Advanced > Additional settings**.



**NOTE:** Additional Wi-Fi settings are for the device, not for a specific wireless network.

- **Regulatory**
  - **Country Selection** - Displays the acquired country code if 802.11d is enabled, else it displays the currently selected country code.
  - **Region code** - Displays the current region code.
- **Band and Channel Selection**
  - **Wi-Fi frequency band** - Set the frequency band to: **Auto** (default), **5 GHz only** or **2.4 GHz only**.
  - **Available channels (2.4 GHz)** - Touch to display the **Available channels** menu. Select specific channels and touch **OK**.
  - **Available channels (5 GHz)** - Touch to display the **Available channels** menu. Select specific channels and touch **OK**.

- **Logging**
  - **Advanced Logging** – Touch to enable advanced logging or change the log directory.
  - **Wireless logs**
    - **Fusion Logger** - Touch to open the **Fusion Logger** application. This application maintains a history of high level WLAN events which helps to understand the status of connectivity.
    - **Fusion Status** - Touch to display live status of WLAN state. Also provides information about the device and connected profile.
- **About**
  - **Version** - Displays the current Fusion information.

### Wi-Fi Direct

Wi-Fi Direct devices can connect to each other without having to go through an access point. Wi-Fi Direct devices establish their own ad-hoc network when required, letting you see which devices are available and choose which one you want to connect to.

1. Go to **Settings**.
2. Touch **Wi-Fi > Wi-Fi preferences > Advanced > Wi-Fi Direct**. The device begins searching for another Wi-Fi Direct device.
3. Under **Peer devices**, touch the other device name.
4. On the other device, select **Accept**.

**Connected** appears on the device. On both devices, in their respective Wi-Fi Direct screens, the other device name appears in the list.

### Bluetooth

Bluetooth devices can communicate without wires, using frequency-hopping spread spectrum (FHSS) radio frequency (RF) to transmit and receive data in the 2.4 GHz Industry Scientific and Medical (ISM) band (802.15.1). Bluetooth wireless technology is specifically designed for short-range (10 m (32.8 ft)) communication and low power consumption.

Devices with Bluetooth capabilities can exchange information (for example, files, appointments, and tasks) with other Bluetooth enabled devices such as printers, access points, and other mobile devices.

The device supports Bluetooth Low Energy. Bluetooth Low Energy is targeted at applications in the healthcare, fitness, security, and home entertainment industries. It provides reduced power consumption and cost while maintaining standard Bluetooth range.

### Adaptive Frequency Hopping

Adaptive Frequency Hopping (AFH) is a method of avoiding fixed frequency interferers, and can be used with Bluetooth voice. All devices in the piconet (Bluetooth network) must be AFH-capable in order for AFH to work. There is no AFH when connecting and discovering devices. Avoid making Bluetooth connections and discoveries during critical 802.11b communications.

AFH for Bluetooth consists of four main sections:

- **Channel Classification** - A method of detecting an interference on a channel-by-channel basis, or pre-defined channel mask.



- Link Management - Coordinates and distributes the AFH information to the rest of the Bluetooth network.
- Hop Sequence Modification - Avoids interference by selectively reducing the number of hopping channels.
- Channel Maintenance - A method for periodically re-evaluating the channels.

When AFH is enabled, the Bluetooth radio “hops around” (instead of through) the 802.11b high-rate channels. AFH coexistence allows enterprise devices to operate in any infrastructure.

The Bluetooth radio in this device operates as a Class 2 device power class. The maximum output power is 2.5 mW and the expected range is 10 m (32.8 ft). A definition of ranges based on power class is difficult to obtain due to power and device differences, and whether in open space or closed office space.



**NOTE:** It is not recommended to perform Bluetooth wireless technology inquiry when high rate 802.11b operation is required.

## Security

The current Bluetooth specification defines security at the link level. Application-level security is not specified. This allows application developers to define security mechanisms tailored to their specific need. Link-level security occurs between devices, not users, while application-level security can be implemented on a per-user basis. The Bluetooth specification defines security algorithms and procedures required to authenticate devices, and if needed, encrypt the data flowing on the link between the devices. Device authentication is a mandatory feature of Bluetooth while link encryption is optional.

Pairing of Bluetooth devices is accomplished by creating an initialization key used to authenticate the devices and create a link key for them. Entering a common personal identification number (PIN) in the devices being paired generates the initialization key. The PIN is never sent over the air. By default, the Bluetooth stack responds with no key when a key is requested (it is up to user to respond to the key request event). Authentication of Bluetooth devices is based-upon a challenge-response transaction. Bluetooth allows for a PIN or passkey used to create other 128-bit keys used for security and encryption. The encryption key is derived from the link key used to authenticate the pairing devices. Also worthy of note is the limited range and fast frequency hopping of the Bluetooth radios that makes long-distance eavesdropping difficult.

Recommendations are:

- Perform pairing in a secure environment
- Keep PIN codes private and do not store the PIN codes in the device
- Implement application-level security.

## Bluetooth Profiles

The device supports the Bluetooth services listed.

**Table 21** Bluetooth Profiles

Profile	Description
Service Discovery Protocol (SDP)	Handles the search for known and specific services as well as general services.

**Table 21** Bluetooth Profiles (Continued)

Profile	Description
Serial Port Profile (SPP)	Allows use of RFCOMM protocol to emulate serial cable connection between two Bluetooth peer devices. For example, connecting the device to a printer.
Object Push Profile (OPP)	Allows the device to push and pull objects to and from a push server.
Advanced Audio Distribution Profile (A2DP)	Allows the device to stream stereo-quality audio to a wireless headset or wireless stereo speakers.
Audio/Video Remote Control Profile (AVRCP)	Allows the device to control A/V equipment to which a user has access. It may be used in concert with A2DP.
Personal Area Network (PAN)	Allows the use of Bluetooth Network Encapsulation Protocol to provide L3 networking capabilities over a Bluetooth link. Only PANU role is supported.
Human Interface Device Profile (HID)	Allows Bluetooth keyboards, pointing devices, gaming devices and remote monitoring devices to connect to the device.
Headset Profile (HSP)	Allows a hands-free device, such as a Bluetooth headset, to place and receive calls on the device.
Hands-Free Profile (HFP)	Allows car hands-free kits to communicate with the device in the car.
Phone Book Access Profile (PBAP)	Allows exchange of Phone Book Objects between a car kit and a mobile device to allow the car kit to display the name of the incoming caller; allow the car kit to download the phone book so you can initiate a call from the car display.
Out of Band (OOB)	Allows exchange of information used in the pairing process. Pairing is completed using the Bluetooth radio, but requires information from the OOB mechanism. Using OOB with NFC enables pairing when devices simply get close, rather than requiring a lengthy discovery process.
Symbol Serial Interface (SSI)	Allows for communication with Bluetooth Imager.
Generic Attribute Profile (GATT)	Provides profile discovery and description services for Bluetooth Low Energy protocol. It defines how attributes are grouped together into sets to form services.
Dial Up Networking (DUN)	Provides a standard to access the Internet and other dial-up services over Bluetooth.
Generic Access Profile (GAP)	Use for device discovery and authentication.
OBject EXchange (OBEX)	Facilitates the exchange of binary objects between devices.

## Bluetooth Power States

The Bluetooth radio is off by default.

- **Suspend** - When the device goes into suspend mode, the Bluetooth radio stays on.
- **Airplane Mode** - When the device is placed in Airplane Mode, the Bluetooth radio turns off. When Airplane mode is disabled, the Bluetooth radio returns to the prior state. When in Airplane Mode, the Bluetooth radio can be turned back on if desired.

## Bluetooth Radio Power

Turn off the Bluetooth radio to save power or if entering an area with radio restrictions (for example, an airplane). When the radio is off, other Bluetooth devices cannot see or connect to the device. Turn on the Bluetooth radio to exchange information with other Bluetooth devices (within range). Communicate only with Bluetooth radios in close proximity.



**NOTE:** To achieve the best battery life, turn off radios when not in use.

### Enabling Bluetooth

1. Swipe down from the Status bar to open the Notification panel.
2. Touch  to turn Bluetooth on.

### Disabling Bluetooth

1. Swipe down from the Status bar to open the Notification panel.
2. Touch  to turn Bluetooth off.

## Discovering Bluetooth Device(s)

The device can receive information from discovered devices without pairing. However, once paired, the device and a paired device exchange information automatically when the Bluetooth radio is on.

1. Ensure that Bluetooth is enabled on both devices.
2. Ensure that the Bluetooth device to discover is in discoverable mode.
3. Ensure that the two devices are within 10 meters (32.8 feet) of one another.
4. Swipe down from the Status bar to open the Quick Access panel.
5. Touch and hold **Bluetooth**.
6. Touch **Pair new device**. The device begins searching for discoverable Bluetooth devices in the area and displays them under **Available devices**.
7. Scroll through the list and select a device. The Bluetooth pairing request dialog box appears.
8. Touch **Pair** on both devices.
9. The Bluetooth device is added to the **Paired devices** list and a trusted (“paired”) connection is established.

## Changing the Bluetooth Name

By default, the device has a generic Bluetooth name that is visible to other devices when connected.

1. Go to **Settings**.
2. Touch **Connected devices** > **Connection preferences** > **Bluetooth**.
3. If Bluetooth is not on, move the switch to turn Bluetooth on.
4. Touch **Device name**.
5. Enter a name and touch **RENAME**.

## Connecting to a Bluetooth Device

Once paired, connect to a Bluetooth device.

1. Go to **Settings**.
2. Touch **Connected devices** > **Connection preferences** > **Bluetooth**.
3. In the list, touch the unconnected Bluetooth device.

When connected, **Connected** appears below the device name.

## Selecting Profiles on the Bluetooth Device

Some Bluetooth devices have multiple profiles.

1. Go to **Settings**.
2. Touch **Connected devices** > **Connection preferences** > **Bluetooth**.
3. In the **Paired Devices** list, touch  next to the device name.
4. Turn on or off a profile to allow the device to use that profile.

## Unpairing a Bluetooth Device

Unpairing a Bluetooth device erases all pairing information.

1. Go to **Settings**.
2. Touch **Connected devices** > **Connection preferences** > **Bluetooth**.
3. In the **Paired Devices** list, touch  next to the device name.
4. Touch **FORGET**.

## Cast

Use **Cast** to mirror the device screen on a Miracast enabled wireless display.

1. Go to **Settings**.
2. Touch **Connected devices** > **Connection preferences** > **Cast**.
3. Touch  > **Enable wireless display**.

The device searches for nearby Miracast devices and lists them.

4. Touch a device to begin casting.

### Near Field Communications

NFC/HF RFID is a short-range wireless connectivity technology standard that enables a secure transaction between a reader and a contactless smartcard.

The technology is based on ISO/IEC 14443 type A and B (proximity), and ISO/IEC 15693 (vicinity), and FeliCa standards, using the HF 13.56 MHz unlicensed band.

The device supports the following operating modes:

- Reader mode
- Card Emulation mode.

Using NFC, the device can:

- Read contactless cards such as contactless tickets, ID cards and ePassport.
- Read and write information to contactless cards such as SmartPosters and tickets, as well as devices with NFC interface such as vending machines.
- Read information from supported medical sensors.
- Pair with supported Bluetooth devices such as printers ring scanners (for example, RS6000), and headsets (for example, HS3100).
- Exchange data with another NFC device.
- Emulate contactless cards such as payment, or ticket, or SmartPoster.

The device NFC antenna is positioned to read NFC cards from the top of the device while the device is being held.

## Reading NFC Cards

Read contactless cards using NFC.

**Figure 27** Reading Cards



1. Launch an NFC enabled application.
2. Hold device as shown.
3. Move the device close to the NFC card until it detects the card.
4. Hold the card steadily until the transaction is complete (usually indicated by the application).

## Enterprise NFC Settings

Improve NFC performance or increase battery life by selecting which NFC features to use on the device.

- **Card Detection Mode** - Select a card detection mode.
  - **Low** - Increases battery life by lowering the NFC detection speed.
  - **Hybrid** - Provides a balance between NFC detection speed and battery life (default).
  - **Standard** - Provides the best NFC detection speed, but reduces battery life.

- **Supported Card Technology** - Select an option to detect only one NFC tag type, increasing battery life, but reducing detection speed.
  - ISO 14443 Type A
  - ISO 14443 Type B
  - FeliCa
  - ISO 15693
- **NFC Debug Logging** - Use to enable or disable debug logging for NFC.
- **Other NFC settings available with Zebra administrator tools (CSP)** - Allows configuration of additional Enterprise NFC Settings through staging tools and Mobile Device Management (MDM) solutions with an MX version that supports the Enterprise NFC Settings Configuration Service Provider (CSP). For more information on using the Enterprise NFC Settings CSP, refer to: [techdocs.zebra.com](https://techdocs.zebra.com).

# Accessories

The TC8300 accessories provide a variety of product support capabilities.

## Device Accessories

This table lists the accessories available for the device.

**Table 22** Accessories

Accessory	Part Number	Descriptions
<b>Cradles</b>		
2-Slot USB Charge Cradle	CRD-TC8X-2SUCHG-01	Provides device and spare battery charging and USB communication with a host computer. Use with power supply, p/n PWR-BGA12V50W0WW and country specific grounded AC line cord.
2-Slot USB Charge Cradle (for DPM only)	CRD-TC8D-2SUCHG-01	Provides device and spare battery charging and USB communication with a host computer. Use with power supply, p/n PWR-BGA12V50W0WW and country specific grounded AC line cord.
5-Slot Charge Only Cradle	CRD-TC8X-5SCHG-01	Charges up to five devices. Use with power supply, p/n PWR-BGA12V108W0WW, DC line cord, p/n 50-16002-029R and country specific grounded AC line cord.
5-Slot Ethernet Cradle	CRD-TC8X-5SETH-01	Provides device charging and provides Ethernet communication for up to five devices. Use with power supply, p/n PWR-BGA12V108W0WW, DC line cord, p/n 50-16002-029R and country specific grounded AC line cord.
5-Slot Charge Only Cradle with Battery Charger	CRD-TC8X-5SC4BC-01	Charges up to four devices and four spare batteries. Use with power supply, p/n PWR-BGA12V108W0WW, DC line cord, p/n 50-16002-029R and country specific grounded AC line cord.
5-Slot Ethernet Cradle with Battery Charger	CRD-TC8X-5SE4BC-01	Provides device charging and provides Ethernet communication for up to four devices. Provides charging for four spare batteries. Use with power supply, p/n PWR-BGA12V108W0WW, DC line cord, p/n 50-16002-029R and country specific grounded AC line cord.
<b>Batteries and Chargers</b>		



**Table 22** Accessories (Continued)

Accessory	Part Number	Descriptions
Battery	BTRY-TC8X-67MA1-01	Replacement battery (single pack).
	BTRY-TC8X-67MA1-10	Replacement battery (10-pack).
	BTRY-TC8X-70MA1-01	Replacement battery (single pack).
	BTRY-TC8X-70MA1-01	Replacement battery (10-pack).
4-Slot Battery Charger	SAC-TC8X-4SCHG-01	Charges up to four spare batteries. Requires power supply, p/n PWR-BGA12V50W0WW and country specific grounded AC line cord.
USB and Charging Cable	CBL-TC8X-USBCHG-01	Provides USB communication and power to the device. Requires power supply PWR-BUA5V16W0WW and country specific un-grounded AC line cord.
<b>Audio Accessories</b>		
Quick Disconnect Audio Cable	CBL-TC8X-AUDQD-01	Snaps onto the device and provides audio to a wired headset with Quick Disconnect connector.
3.5 mm Audio Cable	CBL-TC8X-AUDBJ-01	Snaps onto the device and provides audio to a wired headset with 3.5 mm plug.
<b>Mounting Brackets</b>		
2-Slot Cradle Desktop Stand	BRKT-SCRD-SSDK-01	Use for mounting a 2-Slot cradle on a desk.
5-Slot Cradle Desktop Stand	BRKT-SCRD-MSDK-01	Use for mounting a 5-Slot cradle on a desk or rack.
Rack Mount Bracket	BRKT-SCRD-SMRK-01	Use for mounting a 5-Slot cradle or four 4-Slot Battery Chargers on a rack.
Desktop Stand	MNT-TC8X-DKPH-01	Un-powered desktop presentation stand. Allows to use the device on a flat surface (i.e. desktop) for hands-free scanning.
Cart Mount	MNT-TC8X-CMKT-01	Un-powered cart mount. Allows to use the device on carts with up to 2" diameter rail/bar and allows to use the device on hands-free scanning mode. Includes RAM Mount required for installation.
Forklift Mount	MNT-TC8X-FMKT-01	Un-powered forklift mount. Allows to install the device on a roll bar or square surface of a forklift and allows to use the device on landscape or portrait mode.
Forklift Mount	MNT-TC8X-FHKT-01	Un-powered forklift mount. Allows to install the device on a roll bar or square surface of a forklift and allows to use the device on landscape or portrait mode.
<b>Carrying Solutions</b>		
Hand Strap	SG-TC8X-HDSTP-01	Replacement hand strap.
Wrist Lanyard	50-12500-006	Optional lanyard for holding the device.
Quick Draw Soft Holster	SG-TC8X-QDHLST-01	Use to hold the device. Requires the Universal Belt.
Quick Draw Soft Holster (for DPM only)	G-TC8D-QDHLST-01	Use to hold the device. Requires the Universal Belt.

**Table 22** Accessories (Continued)

Accessory	Part Number	Descriptions
Presentation Soft Holster	SG-TC8X-PMHLST-01	Use to hold the device and for hands-free scanning. Requires the Universal Shoulder Strap or Universal Belt.
Universal Belt	11-08062-02R	Use to hold the Quick Draw Soft Holster or the Presentation Soft Holster.
Universal Shoulder Strap	WA6010	Use to hold the Presentation Soft Holster.
<b>Power Supplies</b>		
Power Supply	PWR-BUA5V16W0WW	Provides power to the device using the USB and Charging Cable. Requires country specific un-grounded AC line cord.
Power Supply	PWR-BGA12V50W0WW	Provides power to the 2-Slot cradles and 4-Slot Spare Battery Charger. Requires country specific grounded AC line cord.
Power Supply	PWR-BGA12V108W0WW	Provides power to the 5-Slot Charge Only Cradle, 5-Slot Ethernet Cradle, 5-Slot Charge Only Cradle with Battery Charger and the 5-Slot Ethernet Cradle with Battery Charger. Requires DC Line Cord, p/n 50-16002-029R and country specific grounded AC line cord.
DC Y Cable	25-85993-01R	Provides power from the PWR-BGA12V108W0WW power supply to two 4-Slot Battery Chargers.
DC Line Cord	50-16002-029R	Provides power from the power supply to the 5-Slot Charge Only Cradle, 5-Slot Ethernet Cradle, 5-Slot Charge Only Cradle with Battery Charge and 5-Slot Ethernet Cradle with Battery Charger.
<b>Miscellaneous</b>		
Stylus	SG-TC7X-STYLUS-03	Stylus for use with the device (3-pack).
Screen Protectors	MISC-TC8X-SCRN-01	Provides additional protection for display (5-pack).
Replacement Condensation Resistant Back Housing	MISC-TC8X-DSCNT-01	Field replaceable desiccant cartridge for condensation resistant TC8300 models.

## Battery Charging

Charge the device with a battery installed or charge spare batteries.

### Main Battery Charging

The device's Charging/Notification LED indicates the status of the battery charging in the device. The 6,700 mAh battery charges from 0 - 90% in less than four hours at room temperature. The 7,000 mAh battery charges from 0 - 90% in less than five hours at room temperature.

## Spare Battery Charging

The Spare battery Charging LED on the cup indicates the status of the spare battery charging. The 6,700 mAh battery charges from 0 - 90% in less than four hours at room temperature. The 7,000 mAh battery charges from 0 - 90% in less than five hours at room temperature.

**Table 23** Spare Battery Charging LED Indicators

State	Indication
Off	The battery is not charging. The battery is not inserted correctly in the cradle or connected to a power source. Cradle is not powered.
Solid Amber	Healthy battery is charging.
Solid Green	Healthy battery charging is complete.
Fast Blinking Red (2 blinks/second)	Charging error, e.g.: <ul style="list-style-type: none"> <li>• Temperature is too low or too high.</li> <li>• Charging has gone on too long without completion (typically eight hours).</li> </ul>
Solid Red	Unhealthy battery is charging or fully charged.

## Charging the Device

1. Insert the device into the slot to begin charging.

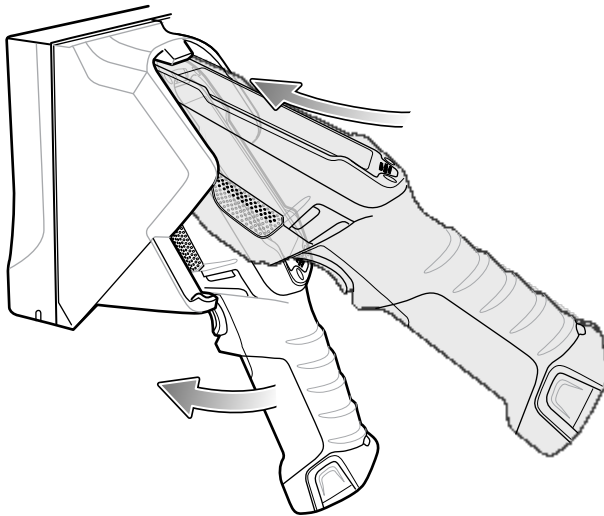

2. Ensure the device is seated properly.

## Charging the Spare Battery

1. Insert the battery into the right slot to begin charging.
2. Ensure the battery is seated properly.

## Charging Temperature

Charge batteries in temperatures from 0 °C to 40 °C (32 °F to 104 °F). The device or cradle always performs battery charging in a safe and intelligent manner. At higher temperatures (e.g. approximately +37 °C (+98 °F)) the device or cradle may for small periods of time alternately enable and disable battery charging to keep the battery at acceptable temperatures. The device and cradle indicates when charging is disabled due to abnormal temperatures via its LED.

## 2-Slot USB Charge Cradle



**CAUTION:** Ensure that you follow the guidelines for battery safety described in [Battery Safety Guidelines](#).

The 2-Slot USB Charge Cradle:

- Provides 5 VDC (nominal) power for operating the device.
- Provide USB communication with a host computer.
- Charges the device's battery.
- Charges a spare battery.

**Figure 28** 2-Slot Charge Only Cradle (Shown on Optional Desk Mount)

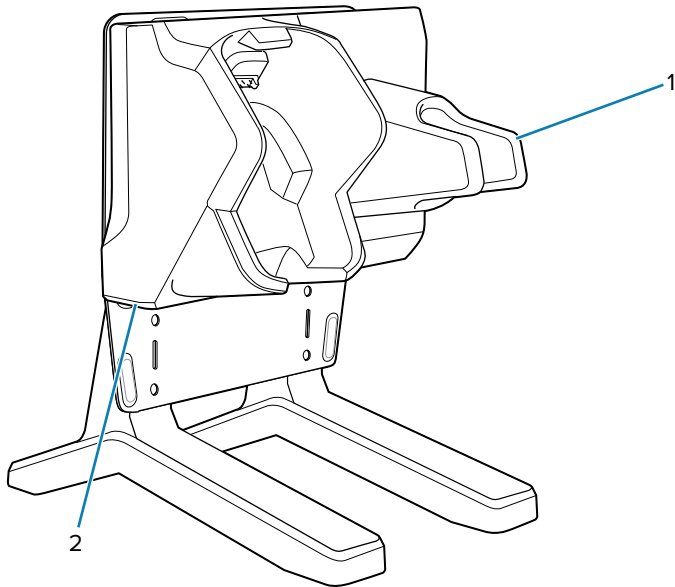

Standard

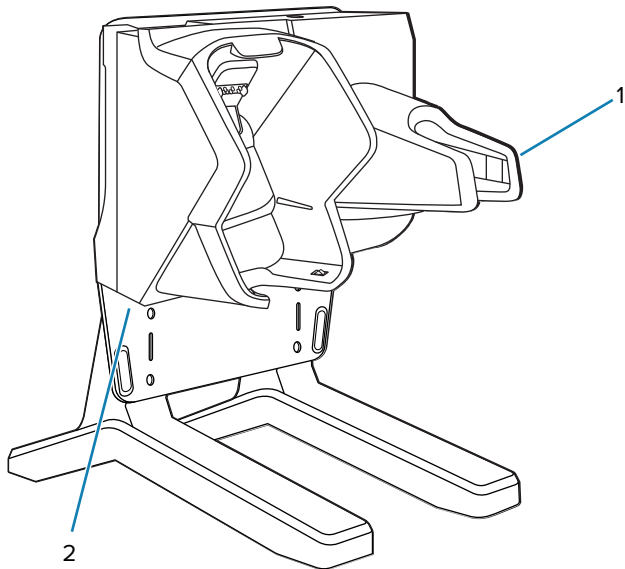

DPM

1	Spare Battery Charging LED
2	Power LED

## Setup

**Figure 29** 2-Slot USB Charge Cradle Setup (Shown on Optional Desk Mount)

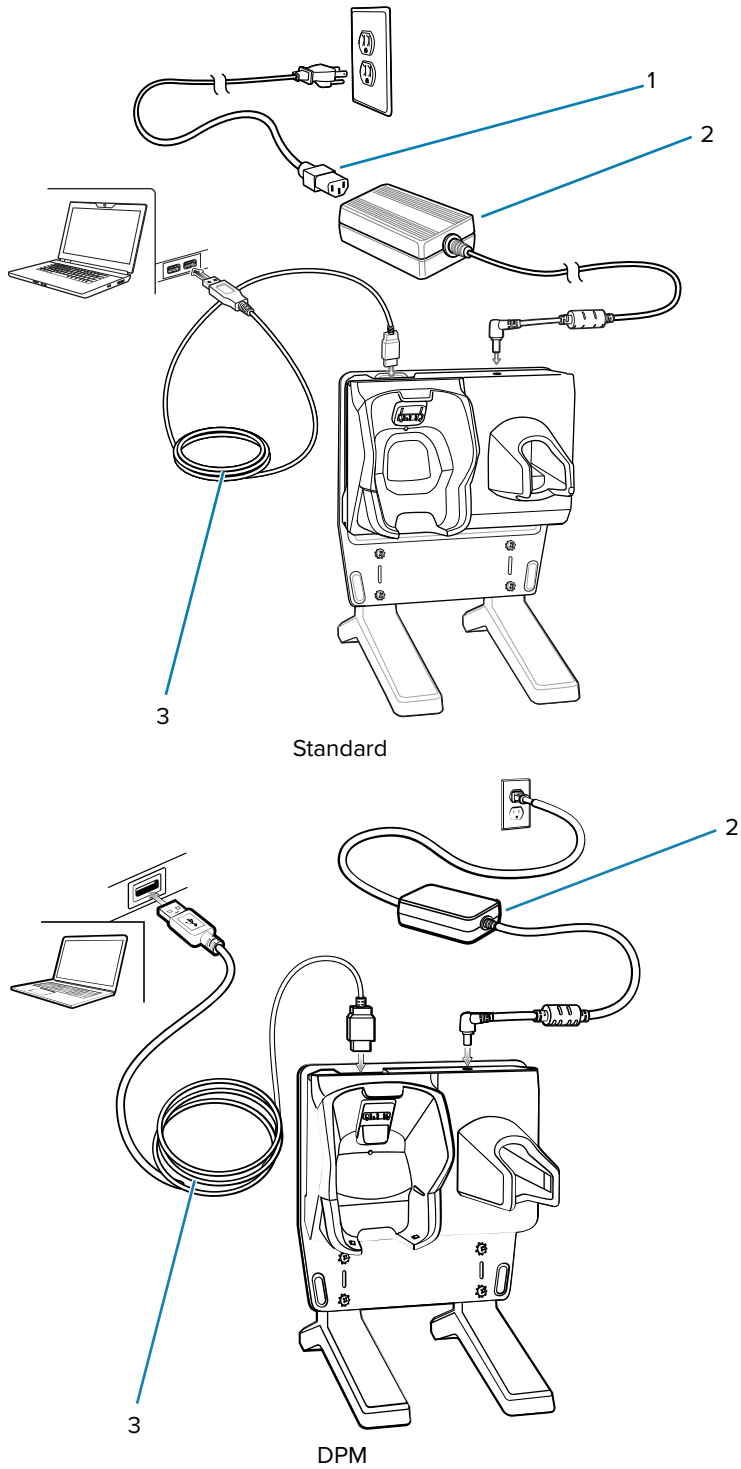

1	AC Line Cord
2	Power Supply

3	USB Cable
---	-----------

## 5-Slot Charge Only Cradle



**CAUTION:** Ensure that you follow the guidelines for battery safety described in [Battery Safety Guidelines](#).

The 5-Slot Charge Only Cradle:

- Provides 5 VDC (nominal) power for operating the device.
- Simultaneously charges up to five devices.

**Figure 30** 5-Slot Charge Only Cradle (Shown on Optional Desk Mount)

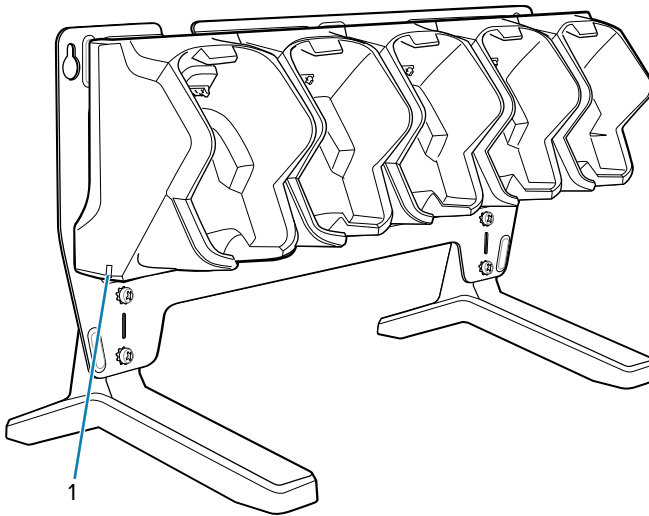

1	Power LED
---	-----------

## Setup

**Figure 31** 5-Slot Charge Only Cradle Setup (Shown on Optional Desk Mount)

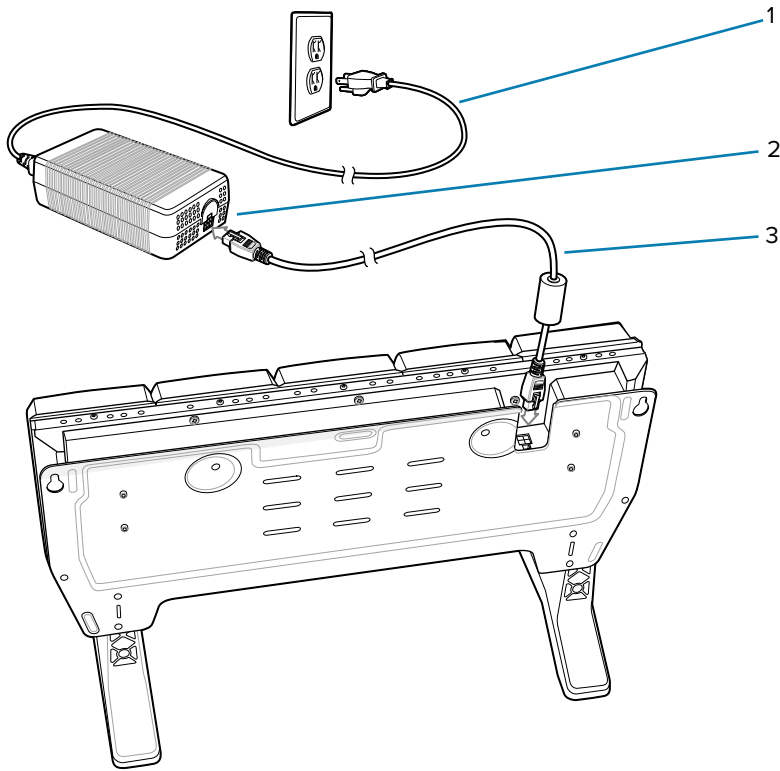

1	AC Line Cord
2	Power Supply
3	DC Line Cord

## 5-Slot Charge Only Cradle with Battery Charger



**CAUTION:** Ensure that you follow the guidelines for battery safety described in [Battery Safety Guidelines](#).

The 4-Slot Charge Only Cradle with Battery Charger:

- Provides 5 VDC (nominal) power for operating the device.
- Simultaneously charges up to four devices.
- Charges up to four spare batteries.



**Figure 32** 5-Slot Charge Only Cradle with Battery Charger (Shown on Optional Desk Mount)

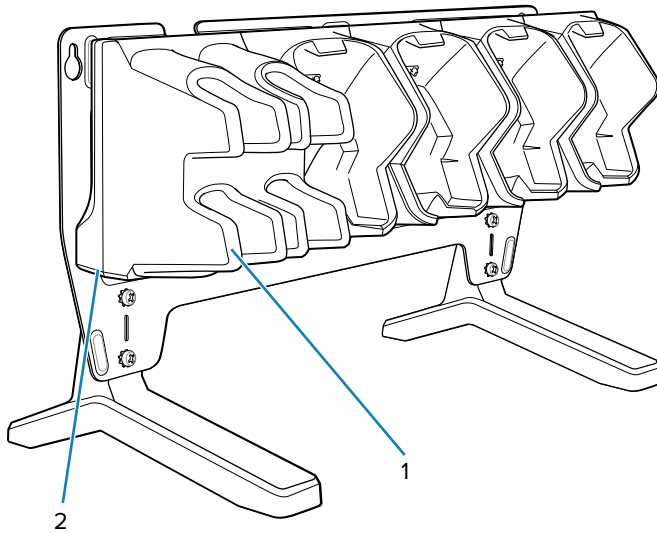

1	Spare Battery Charging LED (4)
2	Power LED

## Setup

**Figure 33** 5-Slot Charge Only Cradle with Battery Charger Setup (Shown on Optional Desk Mount)

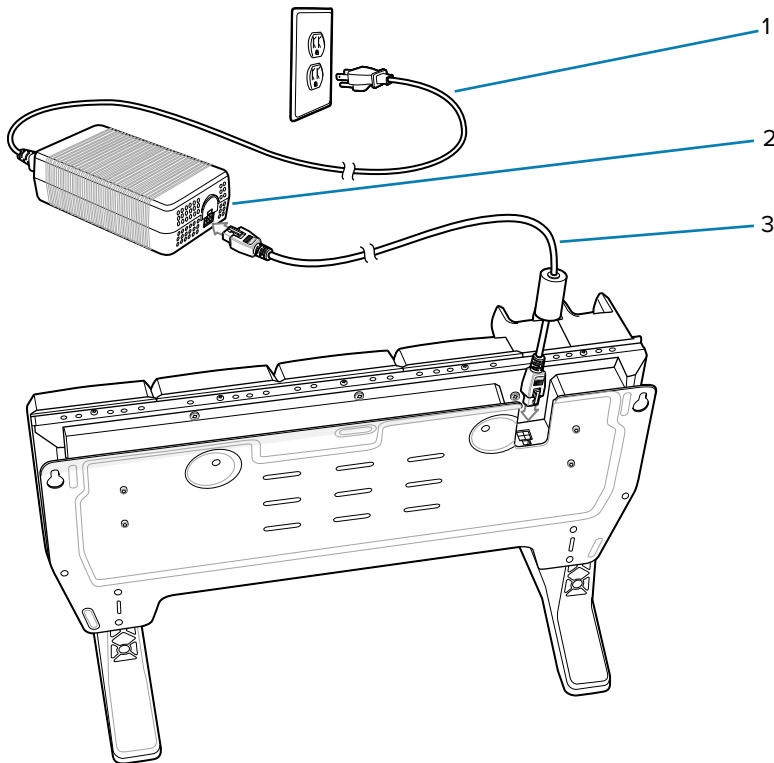

1	AC Line Cord
2	Power Supply
3	DC Line Cord

## 5-Slot Ethernet Cradle



**CAUTION:** Ensure that you follow the guidelines for battery safety described in [Battery Safety Guidelines](#).

The 5-Slot Ethernet Cradle:

- Provides 5.0 VDC (nominal) power for operating the device.
- Connects the device (up to five) to an Ethernet network.
- Simultaneously charges up to five devices.

**Figure 34** 5-Slot Ethernet Cradle (Shown on Optional Desk Mount)

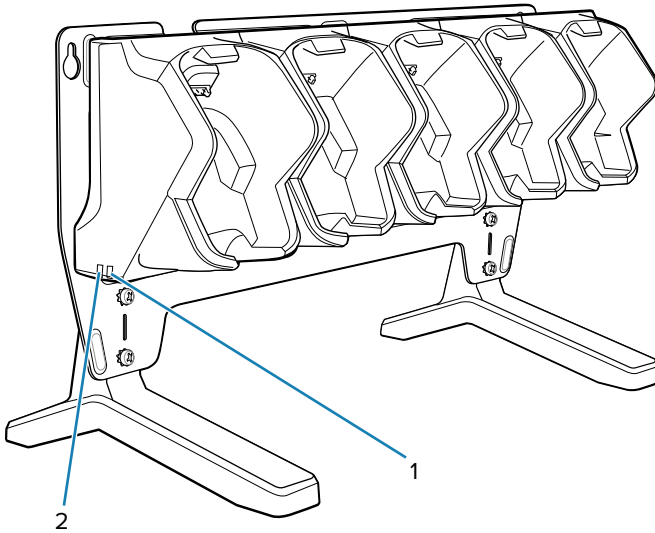

1	1000 LED
2	100/10 LED

## Setup

To setup the 5-Slot Ethernet cradle:

**Figure 35** 5-Slot Ethernet Cradle (Shown on Optional Desk Mount)

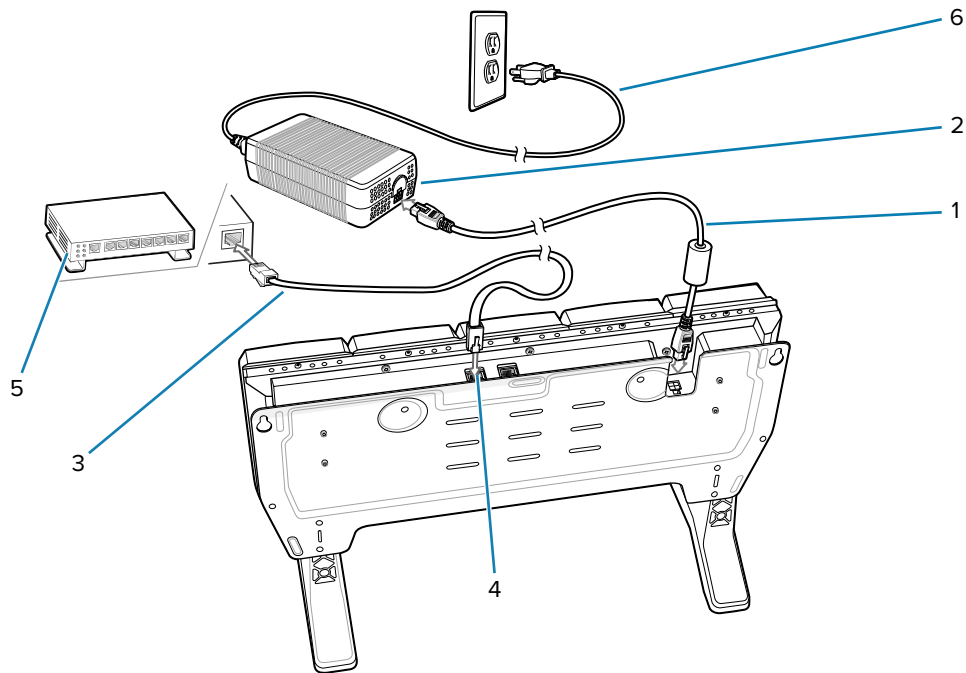

1. Connect the DC line cord (1) to power supply (2).
2. Connect DC line cord (1) to power input on cradle.
3. Connect Ethernet cable (3) to Ethernet port 1 (4) on cradle.
4. Connect the other end of Ethernet cable (3) to the router (5) port.
5. Connect the AC line cord (6) to the power supply (2).
6. Plug the AC line cord (6) into an AC outlet.

## Daisy-chaining Ethernet Cradles

Daisy-chain up to ten 5-Slot Ethernet cradles to connect several cradles to an Ethernet network. Use either a straight or crossover cable. Daisy-chaining should not be attempted when the main Ethernet connection to the first cradle is 10 Mbps as throughput issues will almost certainly result.

1. Connect power (1) to each 5-Slot Ethernet Cradle.
2. Connect an Ethernet cable to port 1 (2) on the back of the first cradle and to the Ethernet switch.
3. Connect an Ethernet cable to port 2 (3) on the back of the first cradle to port 1 (4) on the back of the second cradle.

4. Connect the other end of the Ethernet cable (5) to port 1 of the next 5-Slot Ethernet cradle.

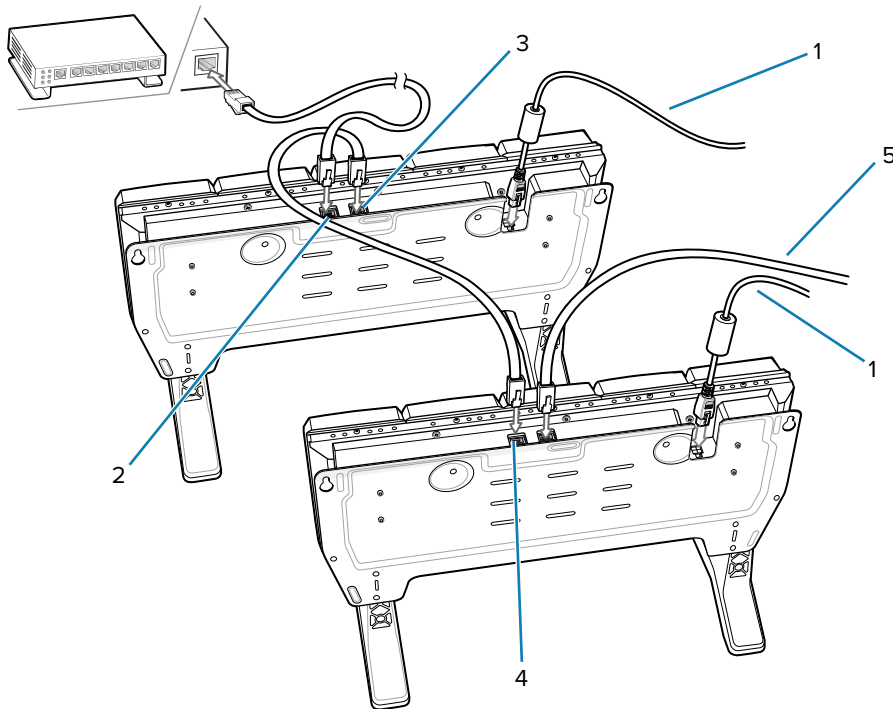

5. Connect additional cradles as described in step 3 and 4.

## Ethernet Settings

The following settings can be configured when using Ethernet communication:

- Proxy Settings
- Static IP.

## Configuring for a Proxy Server

A proxy server is a server that acts as an intermediary for requests from clients seeking resources from other servers. A client connects to the proxy server and requests some service, such as a file, connection, web page, or other resource, available from a different server. The proxy server evaluates the request according to its filtering rules. For example, it may filter traffic by IP address or protocol. If the request is validated by the filter, the proxy provides the resource by connecting to the relevant server and requesting the service on behalf of the client.

It is important for enterprise customers to be able to set up secure computing environments within their companies, making proxy configuration essential. Proxy configuration acts as a security barrier ensuring that the proxy server monitors all traffic between the Internet and the intranet. This is normally an integral part of security enforcement in corporate firewalls within intranets.

To configure the device for a proxy server:

1. Swipe down from the Status bar to open the Quick Access panel and then touch .
2. Touch **Network & Internet > Ethernet**.
3. Place the device into the Ethernet cradle slot.

4. Slide the switch to the **On** position.
5. Touch and hold **eth0** until the menu appears.
6. Touch **Modify proxy**.
7. Touch the **Proxy** drop-down list and select **Manual**.
8. In the **Proxy hostname** text box, enter the address of the proxy server.
9. In the **Proxy port** text box, enter the port number for the proxy server.
10. In the **Bypass proxy for** text box, enter addresses for web sites that are not required to go through the proxy server. Use the separator “|” between addresses. Do not use spaces or carriage returns between addresses.
11. Touch **Modify**.
12. Touch Home button.

## Configuring Ethernet Static IP Address

The device includes Ethernet cradle drivers. After inserting the device, configure Ethernet connection:

1. Swipe down from the Status bar to open the Quick Access panel and then touch .
2. Touch **Network & Internet > Ethernet**.
3. Place the device into the Ethernet cradle slot.
4. Slide the switch to the **On** position.
5. Touch **eth0**.
6. Touch **Disconnect**.
7. Touch **eth0**.
8. Touch and hold the IP Settings drop-down list and select **Static**.
9. In the **IP address** field, enter the proxy server address.
10. If required, in the **Gateway** text box, enter a gateway address for the device.
11. If required, in the **Netmask** field, enter the network mask address.
12. If required, in the **DNS address** fields, enter a Domain Name System (DNS) address.
13. Touch **Connect**.
14. Touch Home button.

## LED Indicators

There are two green LEDs on the side of the cradle and on each Ethernet port. These green LEDs light and blink to indicate the data transfer rate.



**Table 24** LED Data Rate Indicators

Data Rate	1000 LED	100/10 LED
1 Gbps	On/Blink	Off
100 Mbps	Off	On/Blink

**Table 24** LED Data Rate Indicators (Continued)

Data Rate	1000 LED	100/10 LED
10 Mbps	Off	On/Blink

## Establishing Ethernet Connection

1. Swipe down from the status bar to open the quick access panel and then touch  > **Network & Internet** > **Ethernet**.
2. Slide the Ethernet switch to the **ON** position.
3. Insert the device into a slot.
4. The  icon appears in the Status bar.
5. Touch **Eth0** to view Ethernet connection details.

## 5-Slot Ethernet Cradle with Battery Charger



**CAUTION:** Ensure that you follow the guidelines for battery safety described in [Battery Safety Guidelines](#).

The 5-Slot Ethernet Cradle with Battery Charger:

- Provides 5.0 VDC (nominal) power for operating the device.
- Connects the device (up to five) to an Ethernet network.
- Simultaneously charges up to four devices.
- Simultaneously charges up to four spare batteries.

**Figure 36** 5-Slot Ethernet Cradle with Battery Charger (Shown on Optional Desk Mount)

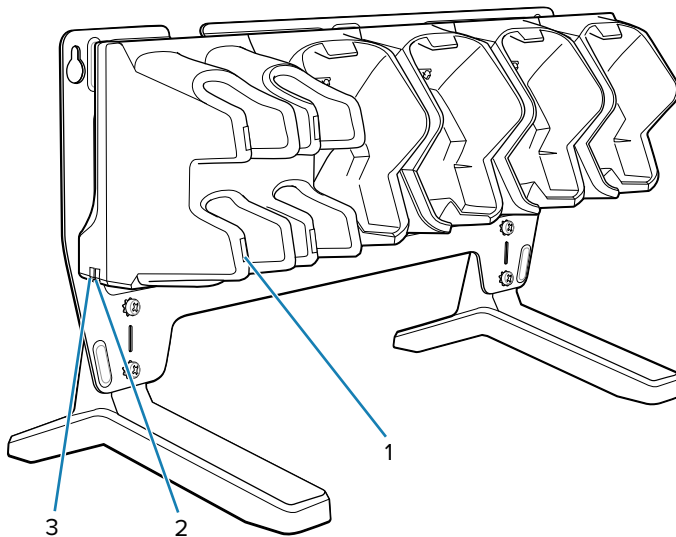

1	Spare Battery Charging LED (4)
---	--------------------------------

2	1000 LED
3	100/10 LED

## Setup

To setup the 5-Slot Ethernet cradle:

**Figure 37** 5-Slot Ethernet Cradle with Battery Charger Setup (Shown on Optional Desk Mount)

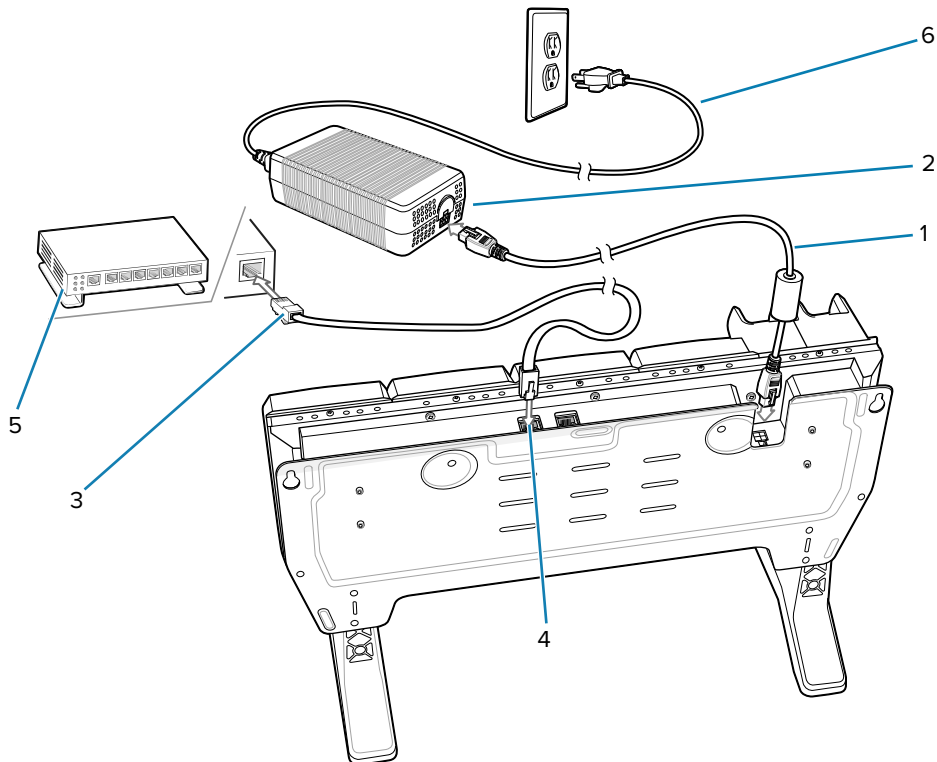

1. Connect the DC line cord (1) to the power supply (2).
2. Connect DC line cord (1) to the power input on the cradle.
3. Connect Ethernet cable (3) to Ethernet port 1 (4) on the cradle.
4. Connect the other end of the Ethernet cable to the router port (5).
5. Connect the AC line cord (6) to the power supply (2).
6. Plug the AC line cord (6) into an AC outlet.



## Daisy-chaining Ethernet Cradles

See [Daisy-chaining Ethernet Cradles](#) on page 131.

## Ethernet Settings

See [Ethernet Settings](#) on page 132.

## Establishing Ethernet Connection

1. Swipe down from the status bar to open the quick access panel and then touch  > **Network & Internet** > **Ethernet**.
2. Slide the Ethernet switch to the **ON** position.
3. Insert the device into a slot.
4. The  icon appears in the Status bar.
5. Touch **Eth0** to view Ethernet connection details.

## 4-Slot Battery Charger

This section describes how to use the 4-Slot Battery Charger to charge up to four device batteries.

**Figure 38** 4-Slot Battery Charger

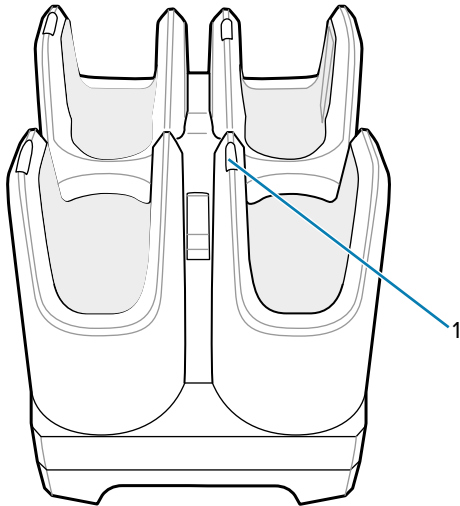

1	Spare Battery Charging LED (4)
---	--------------------------------



## Four Slot Battery Charger Setup

**Figure 39** Four Slot Battery Charger Power Setup

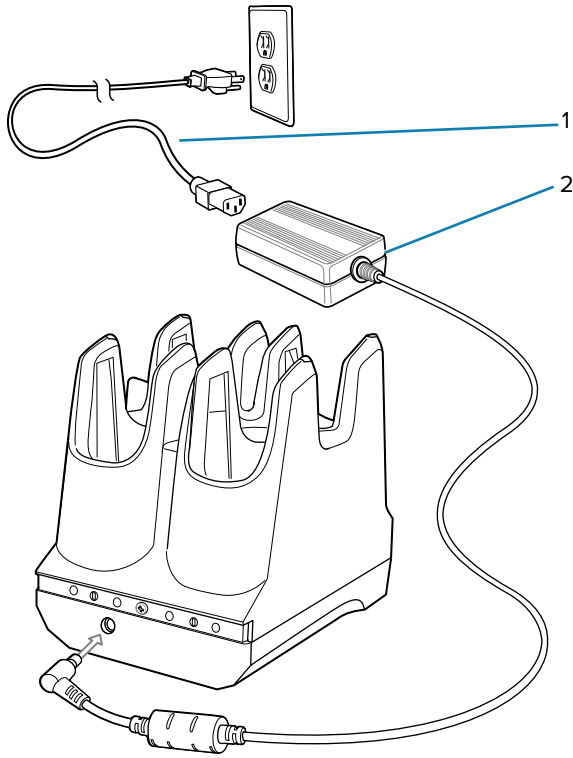

1	AC Line Cord
2	Power Supply

## Battery Charging

Charge the device with a battery installed or charge spare batteries.

### Charging Spare Batteries

1. Connect the charger to a power source.
2. Insert the battery into a battery charging well and gently press down on the battery to ensure proper contact.

## 2-Slot Desk Bracket

Use the 2-Slot Desk Mount to mount the 2-Slot USB Charging cradle in a vertical position.

**Figure 40** 2-Slot Desk Mount

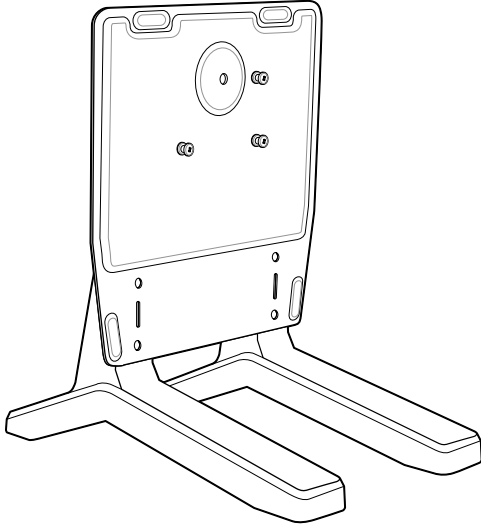

### 2-Slot Desk Mount Assembly

To assemble the 2-Slot Desk Mount:

1. Align plate mounting holes with holes in feet.
2. Secure plate (1) to feet (2) with four screws (3) and four washers.

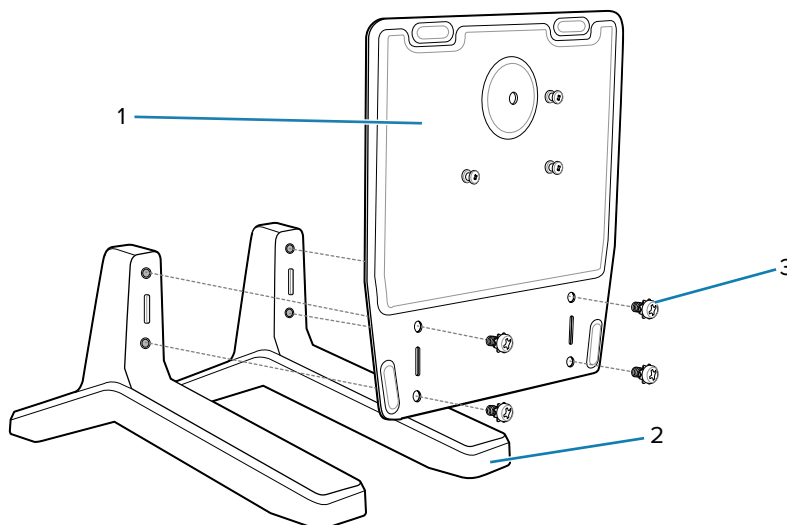

## Mounting Cradle

To mount the cradle:

1. Align mounting slots on bottom of cradle with studs (1) on plate.

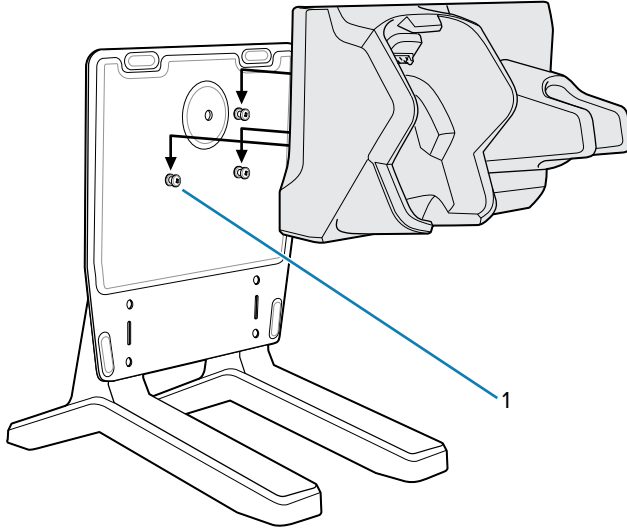

2. Secure cradle to plate using safety screw (1).

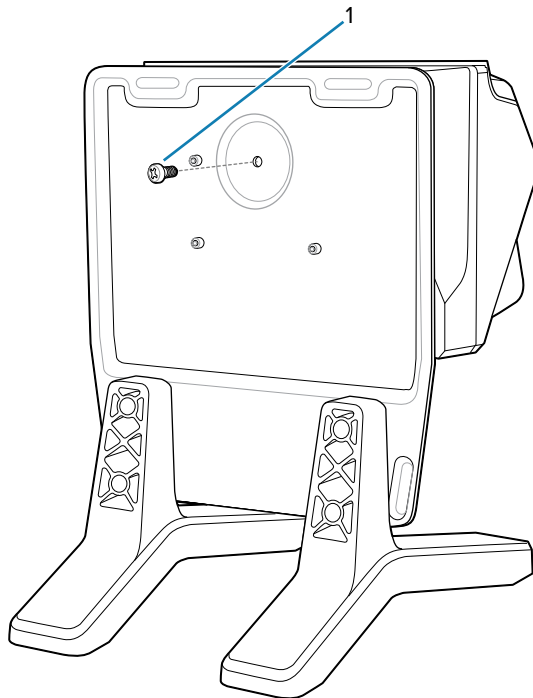

## 5-Slot Desktop Bracket

Use the 5-Slot Desk Mount to mount the 5-Slot Charge Only cradles or the 5-Slot Ethernet cradles in a vertical position.

**Figure 41** 5-Slot Desk Mount

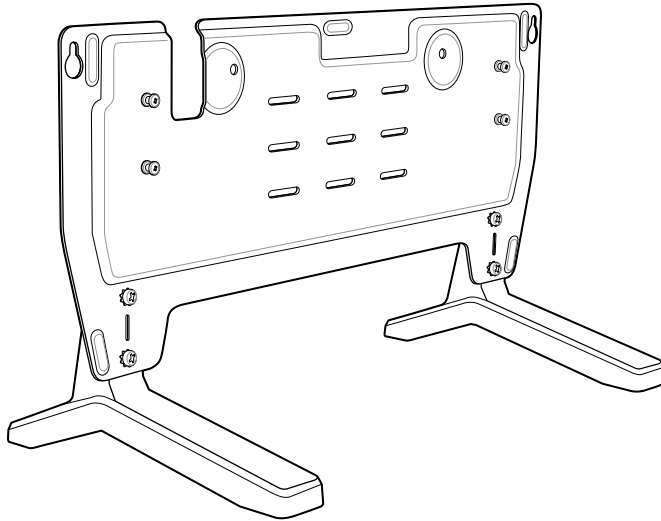

### 5-Slot Desk Mount Assembly

To assemble the 5-Slot Desk Mount:

1. Align plate mounting holes with holes in feet.

2. Secure plate (1) to feet (2) with four screws (3) and four washers.

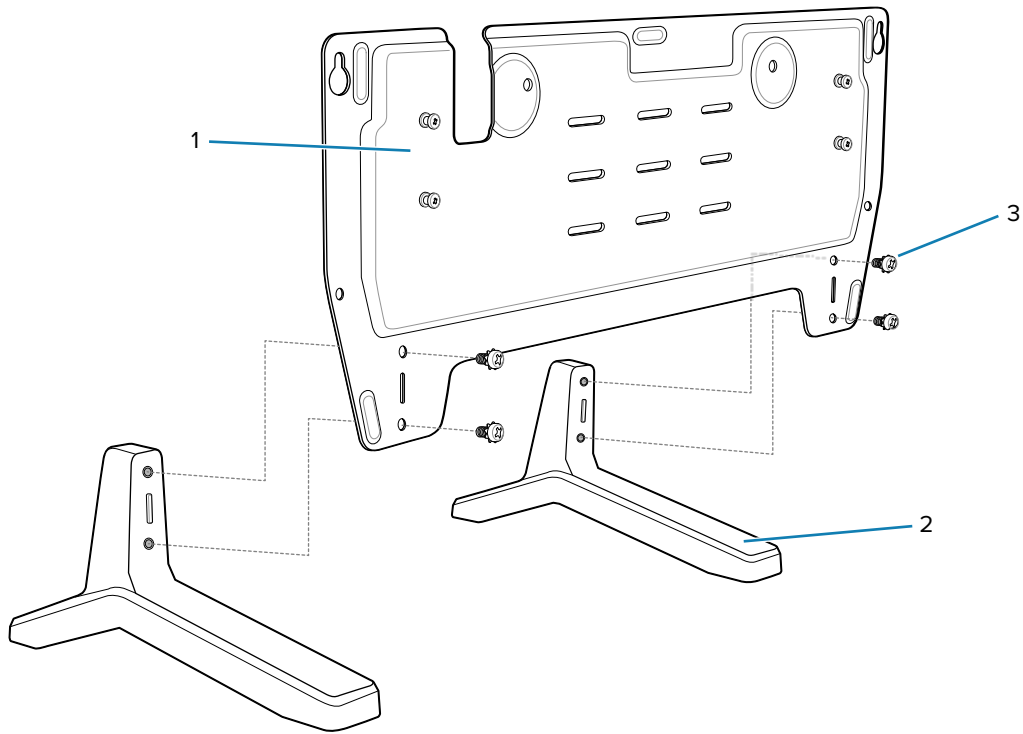

## Mounting Cradle

To mount the cradle:

1. Align mounting slots on bottom of cradle with studs (1) on plate.

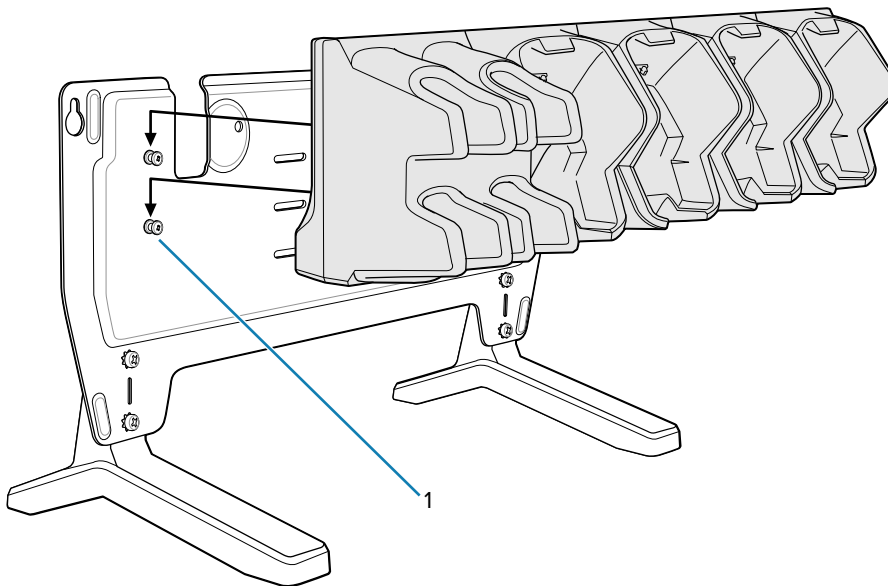

2. Secure cradle to plate using two safety screws (1).

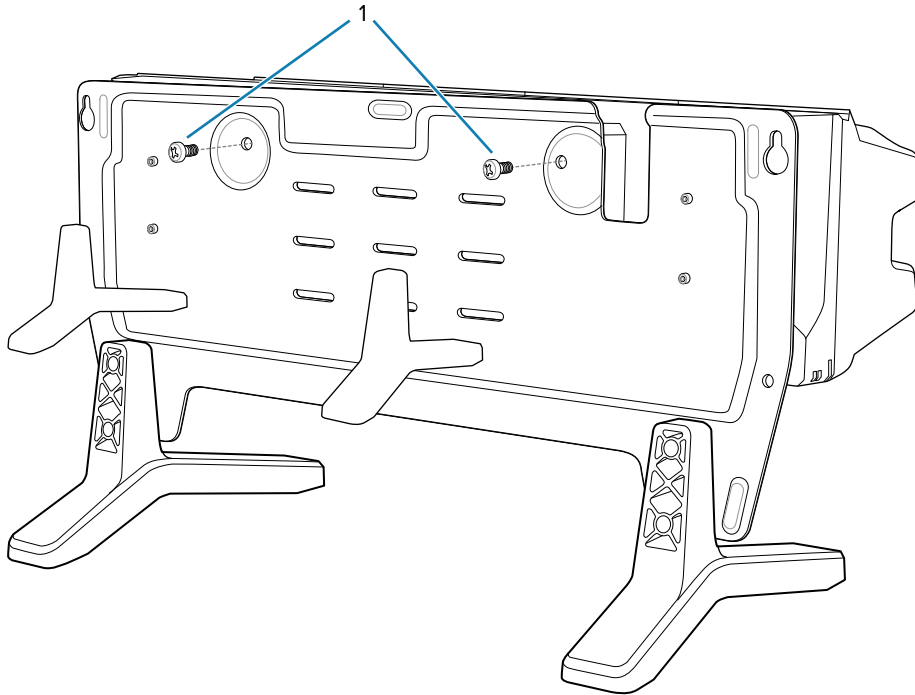

## Cart Mount

Use the Cart Mount to hold the device and perform hands-free scanning in Presentation Mode.

**Figure 42** Cart Mount

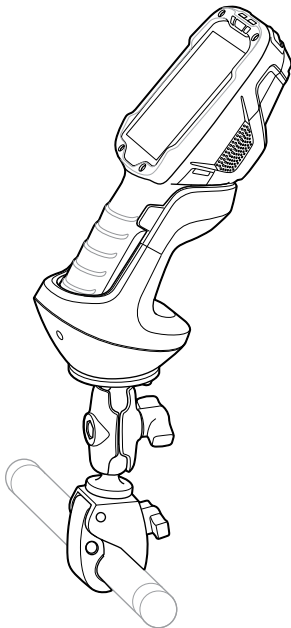

## Installing Cart Mount

To assemble the Cart Mount and RAM Mount:

1. Secure the RAM Mount ball base (1) to the bottom of the Cart Mount using four screws and four washers (provided).
2. Insert the socket arm (2) to the ball base and claw base (3).
3. Slightly tighten the knob on the socket arm (2).

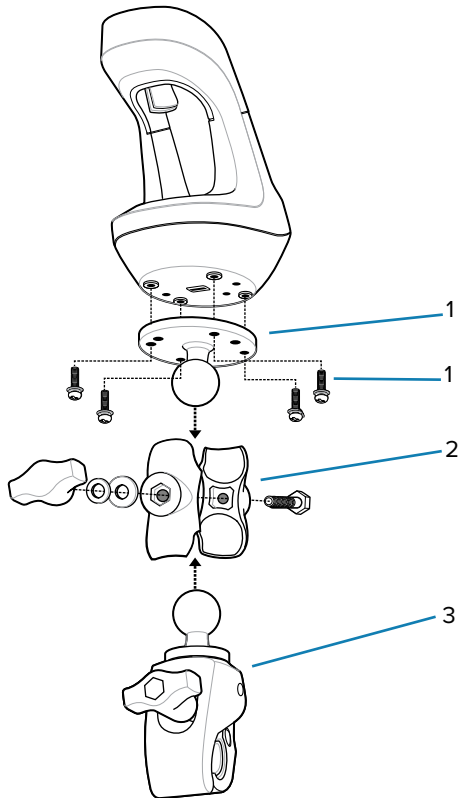

4. Squeeze the claw base and install it on a cart rail.

5. Position the Cart Mount and tighten the claw knob (1) and socket arm knob (2).

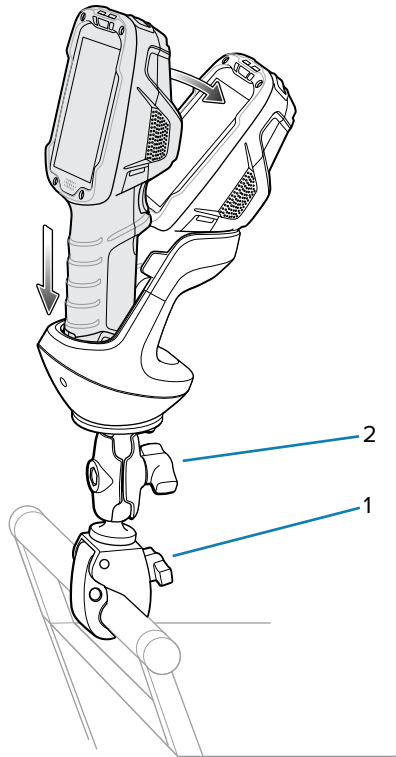

6. Insert the device handle into the Cart Mount cradle and rotate into the cradle.

## Installing 5-Slot Cradle Rack

Use the Rack/Wall Mount Bracket to mount a 5-slot cradle on a rack. When installing on a rack, first assemble the bracket and cradles/chargers and then install the assembly on the rack.

1. Place the power supply (1) in bottom tray.
2. Connect AC line cord (2) to power supply (1).
3. Connect DC line cord (3) to power supply (1).

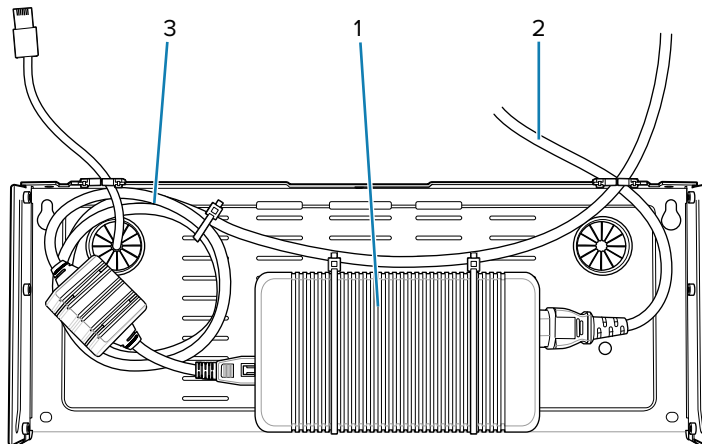



- Secure power supply and cables to bottom tray with tie wraps.



**NOTE:** Ensure tie wrap buckle is on side of power supply. Tie wrap buckle on top of power supply interferes with top tray.

- Route cables through cable slots.
- Secure four M2.5 studs (1) to top tray as shown.

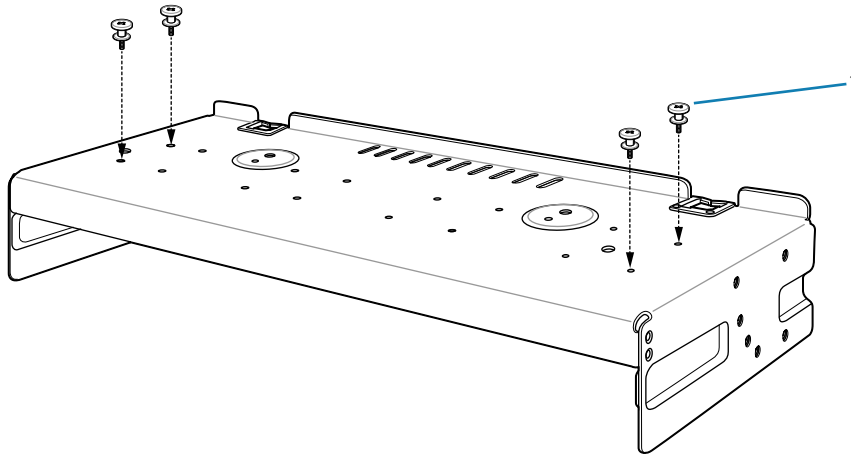

- Align and install 5-Slot cradle onto studs of top tray.

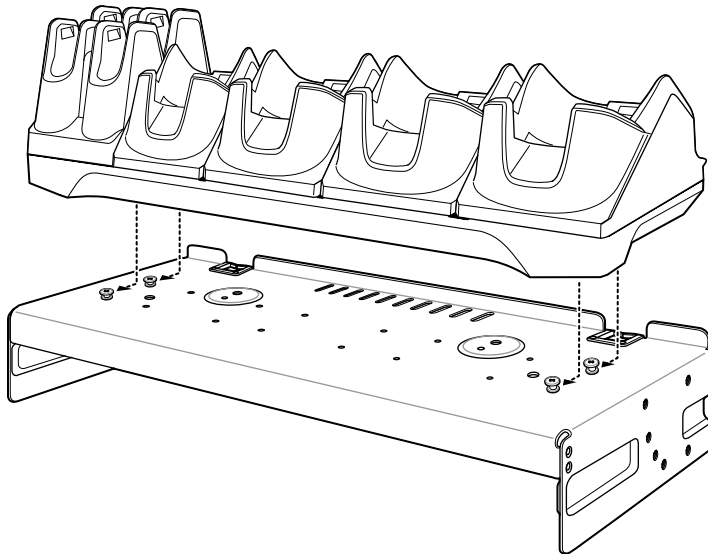

8. Secure cradle to top tray with two M2.5 safety screws (1).

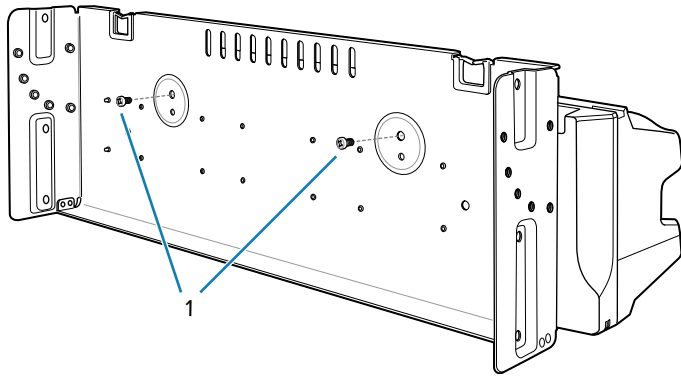

9. Slide top tray onto bottom tray.

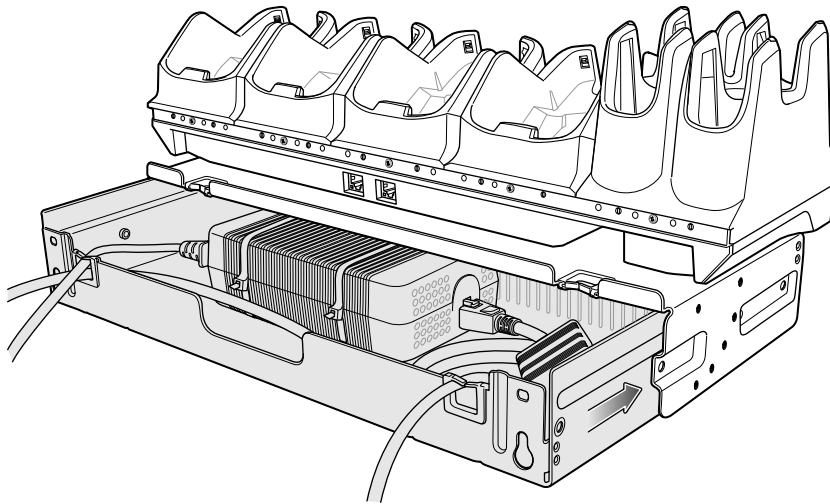

10. Connect cables to cradle.

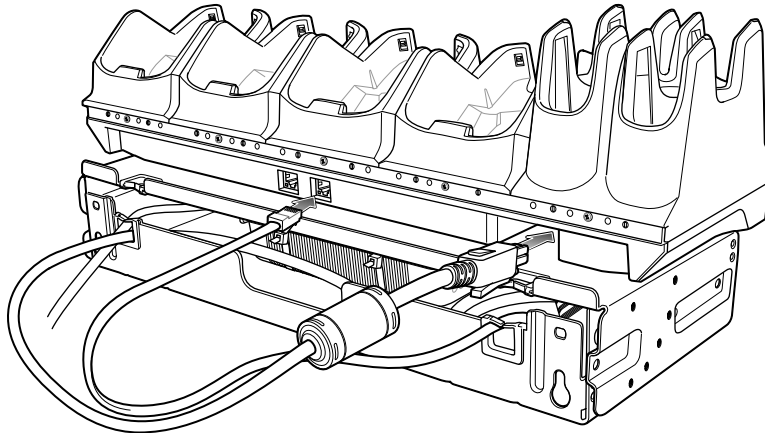

11. Secure top tray to bottom tray with 4 M5 screws (two on each side).

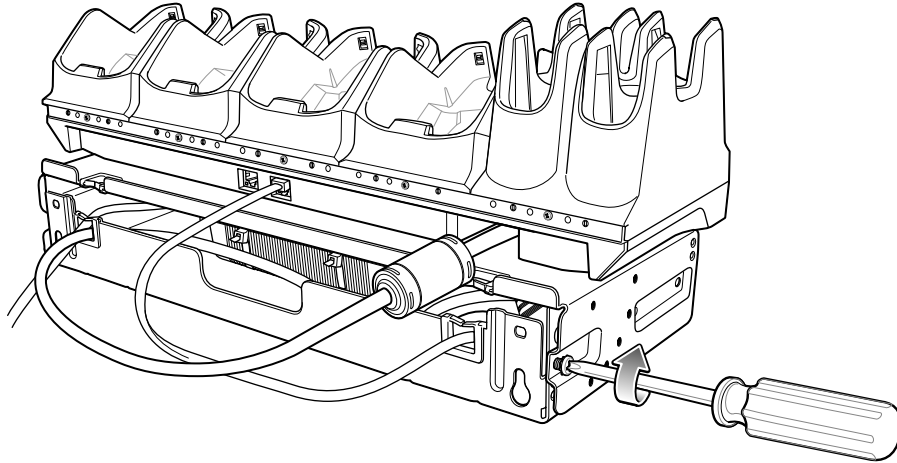

See [Rack Mount Installation on page 132](#) for installing the bracket assembly onto a rack.

### Installing 4-Slot Battery Chargers Rack

Use the Rack/Wall Mount Bracket to mount four 4-Slot Battery Chargers on a rack. When installing on a rack, first assemble the bracket and chargers and then install the assembly on the rack.

1. Place one power supply (1) horizontally in bottom tray.
2. Place one power supply (2) vertically in bottom tray.
3. Connect AC line cords (3) to power supplies.
4. Connect DC line cords to power supplies.
5. Secure power supplies and cables to bottom tray with tie wraps.

6. Route cables through cable slots.

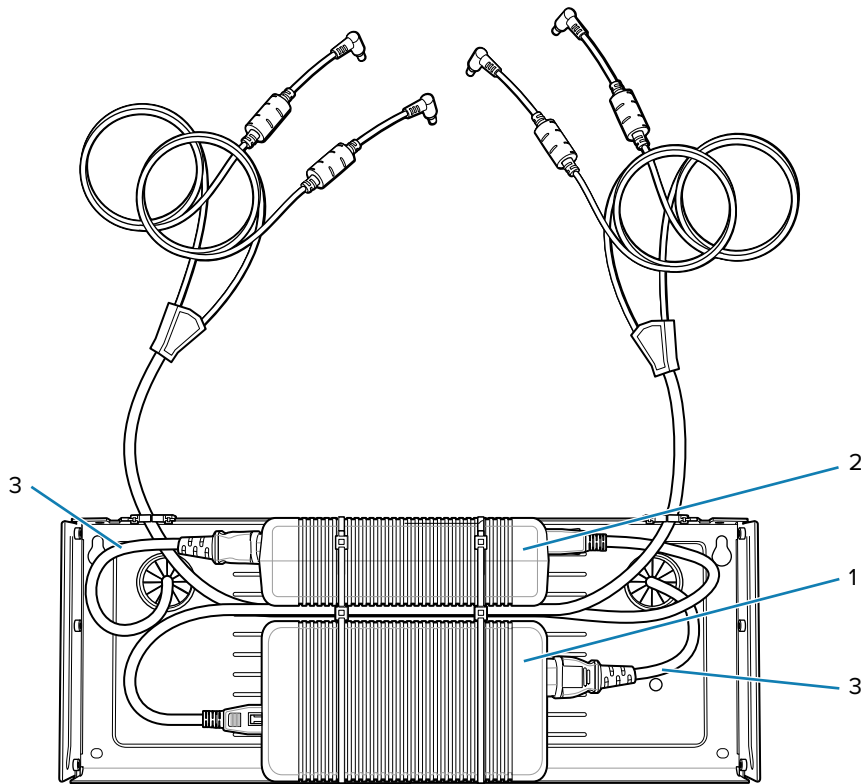

7. Slide top tray onto bottom tray until top tray touches vertical power supply.

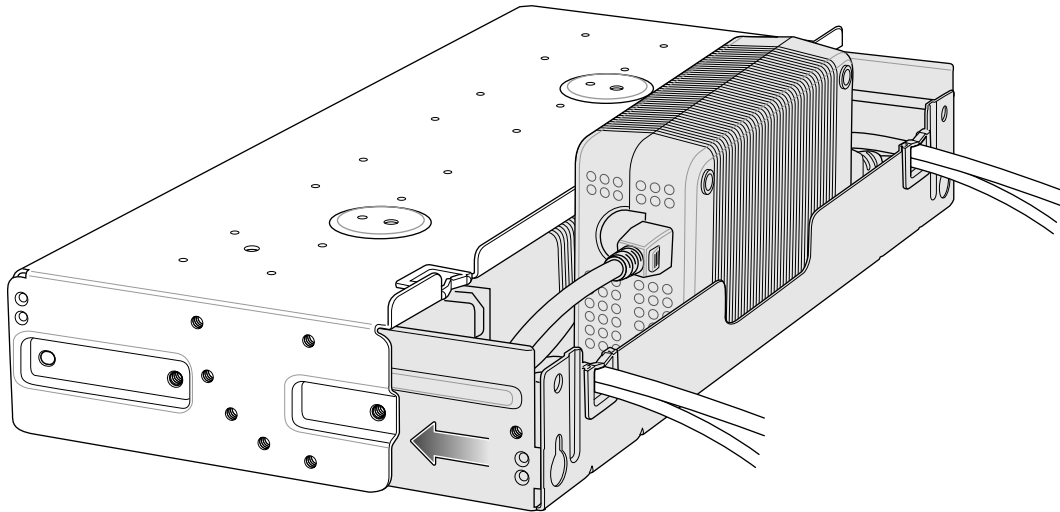

8. Install 16 M2.5 (1) studs onto top tray as shown below.

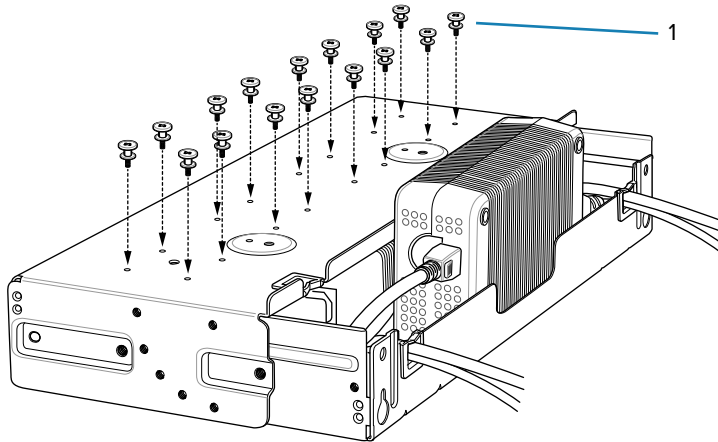

9. Align and install 4-Slot Battery Charger onto four studs.

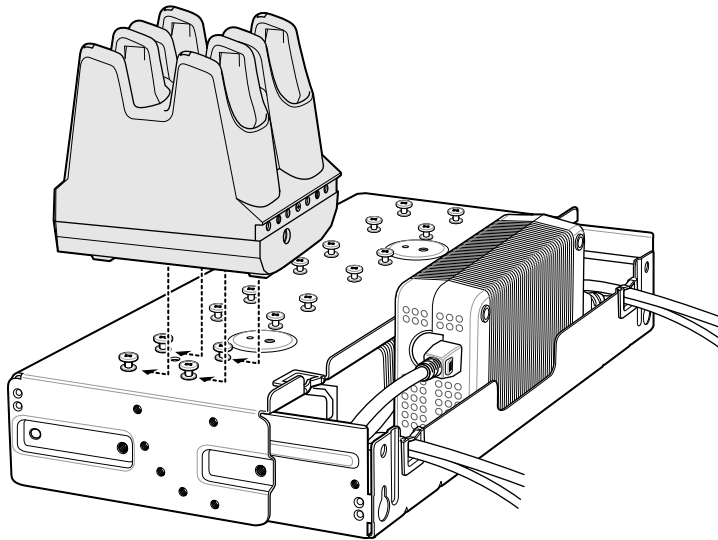

10. Connect DC Y cables (1) to four 4-Slot Battery Chargers.

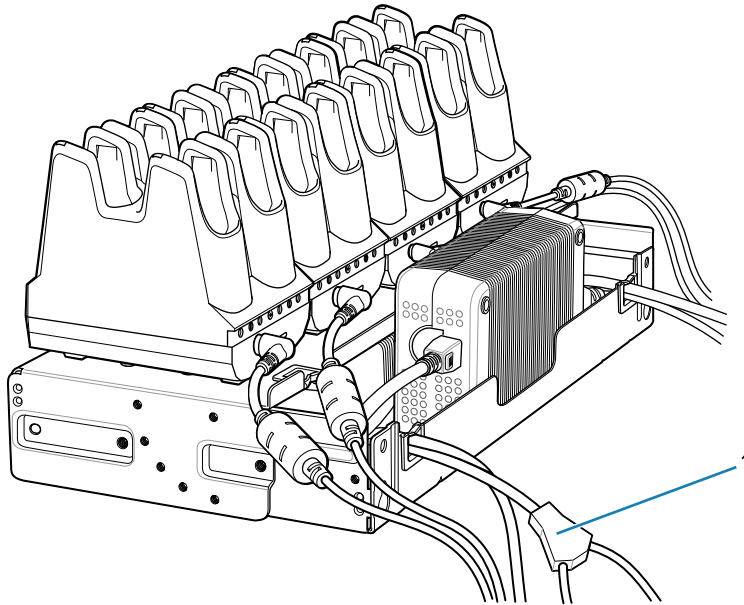

11. Secure top tray to bottom tray with four M5 screws (two on each side).

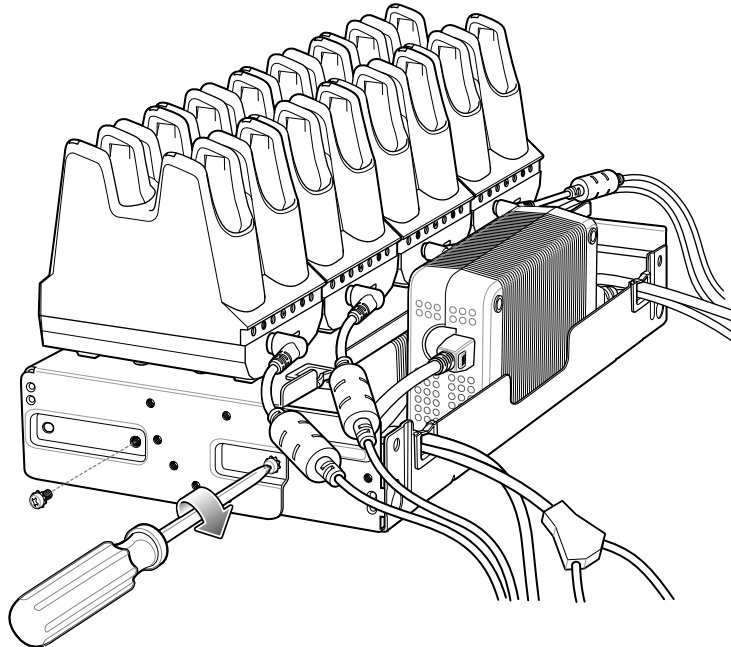

See [Installing Rack Mount](#) on page 150 for installing the bracket onto a rack.

## Installing Rack Mount



**NOTE:** Use screws provided with rack system. Refer to rack user documentation for instructions.

1. Secure mounting brackets to both sides of top tray with four M5 screws (two on each side).
  - For 5-Slot cradles, position the flange for vertical installation.

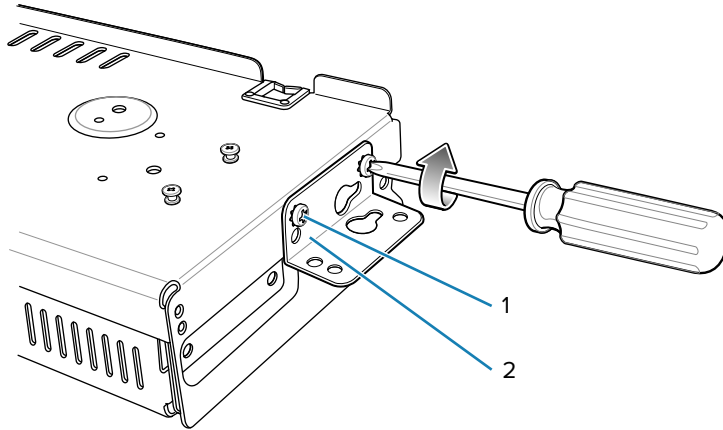

1	Top screw hole
2	Flange

- For 4-Slot Battery Chargers, position the flange for 25° installation.

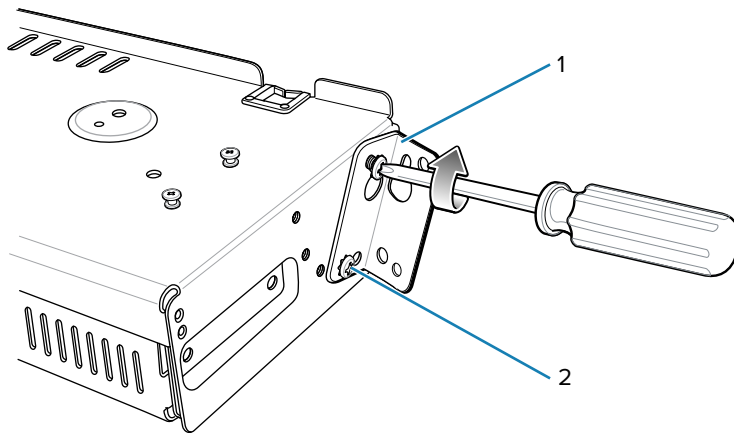

1	Flange
2	Fourth Screw Hole

2. Install two rack system screws for top of mounting brackets. The screw heads should protrude half way from the rail.

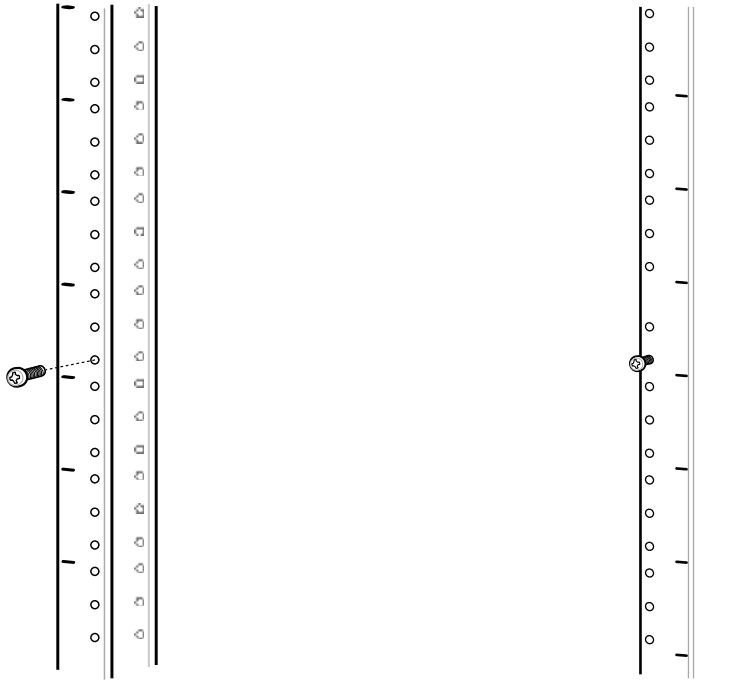

3. Align the mounting bracket's top mounting key holes with the screws.
4. Place the brackets on the screws.

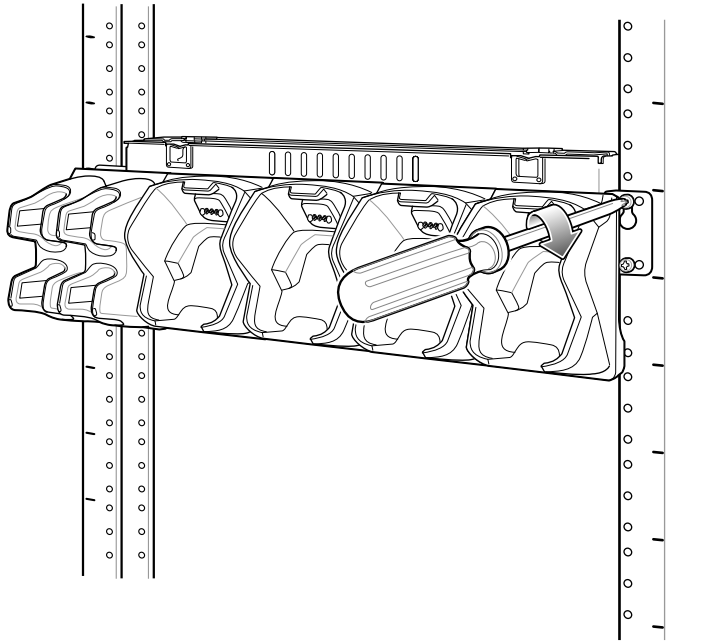

5. Secure the top screws.
6. Install bottom screws and tighten screws.



7. Route cables and connect to power source.



**NOTE:** Installer should ensure that all building codes are followed when connecting the power supplies to an AC power source.

While installing the brackets, power supplies and cables:

- Use tie wraps to secure cables to the bracket and rails.
- Coil cables wherever possible.
- Route power cables along the rails.
- Route inter-cradle cables to the side rails and then from the rails to the bracket.

## Installing 5-Slot Cradle Wall

Use the Rack/Wall Mount Bracket to mount a cradle on a wall. When installing on a wall, first assemble the bottom tray, install the bottom tray on the wall and then assemble the top tray.

Use mounting hardware (screws and/or anchors) appropriate for the type of wall mounting the bracket onto. The Mount Bracket mounting slots dimensions are 5 mm (0.2 inches). Fasteners must be able to hold a minimum of 20 kg (44 lbs).

For proper installation consult a professional installer. Failure to install the bracket properly can possibly result in damage to the hardware.

### Bottom Tray Assembly

See steps 1 through 5 in [Installing 5-Slot Cradle Rack](#) on page 144.

### Bracket Wall Mounting

1. Drill holes and install anchors according to the template supplied with the bracket.

2. Install two screws for bottom of bracket. The screw heads should protrude 2.5 mm (0.01") from the wall.

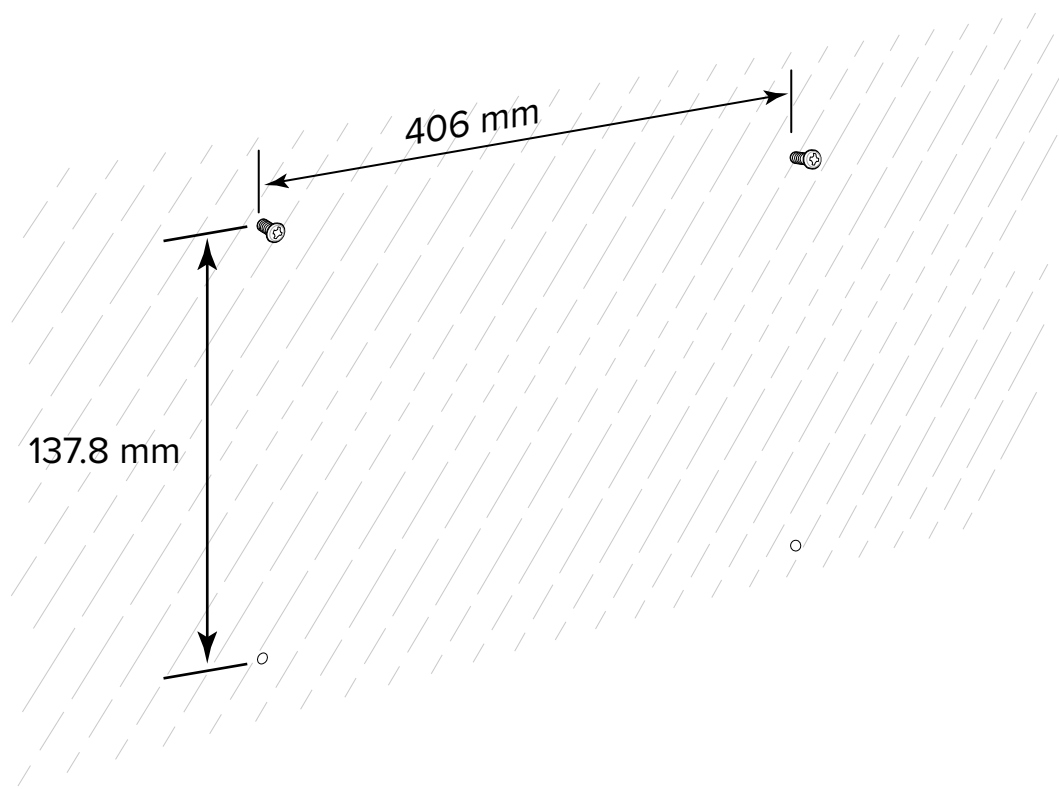

3. Align the mounting bracket's bottom mounting key holes with the screws.
4. Hang the bracket on the screws.

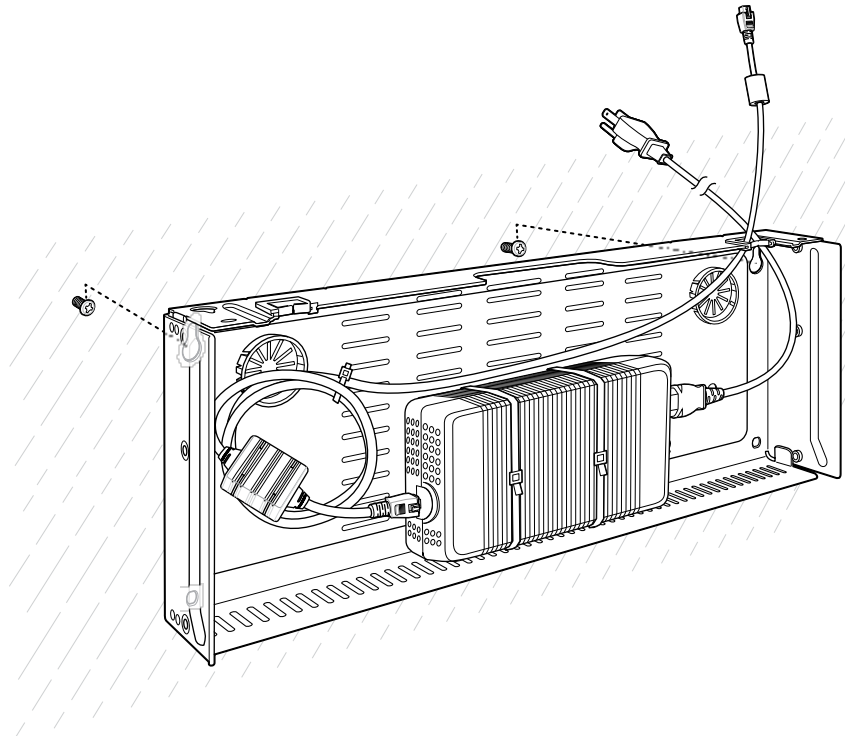

5. Install two top screws.
6. Tighten all screws.

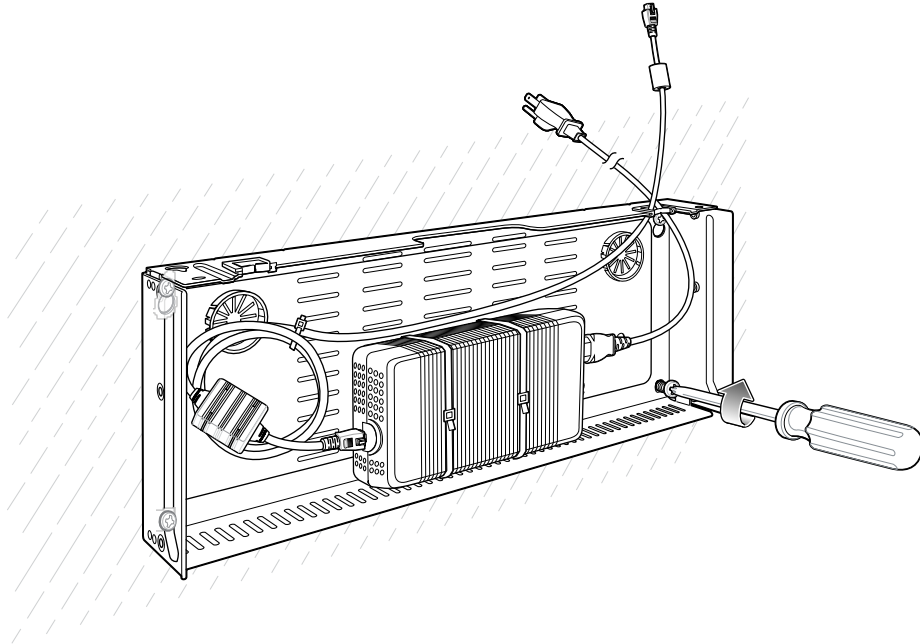

7. Assemble the top tray. See steps 6 through 8 in [Installing 5-Slot Cradle Rack](#) on page 144.
8. Slide the assembled top tray onto bottom tray.
9. Connect cables to cradle.
10. Secure top tray to bottom tray with four M5 screws (two on each side).
11. Route cables and connect to power source.



**NOTE:** Installer should ensure that all building codes are followed when connecting the power supplies to an AC power source.

While installing the brackets, power supplies and cables:

- Use tie wraps to secure cables to the bracket.
- Coil cables wherever possible.
- Route power cables along wall and secure.

## 4-Slot Battery Charger Wall Installation

Use the Rack/Wall Mount Bracket to mount four 4-Slot Battery Chargers a cradle on a wall. When installing on a wall, first assemble the bottom tray, install the bottom tray on the wall and then assemble the top tray.

Use mounting hardware (screws and/or anchors) appropriate for the type of wall mounting the bracket onto. The Mount Bracket mounting slots dimensions are 5 mm (0.2 inches). Fasteners must be able to hold a minimum of 20 Kg (44 lbs).

For proper installation consult a professional installer. Failure to install the bracket properly can possibly result in damage to the hardware.

## Bottom Tray Assembly

See steps 1 through 5 in [Installing 4-Slot Battery Chargers Rack](#) on page 147.

## Bracket Wall Mounting

1. Drill holes and install anchors according to the template supplied with the bracket.
2. Install two screws for bottom of bracket. The screw heads should protrude 2.5 mm (0.01") from the wall.

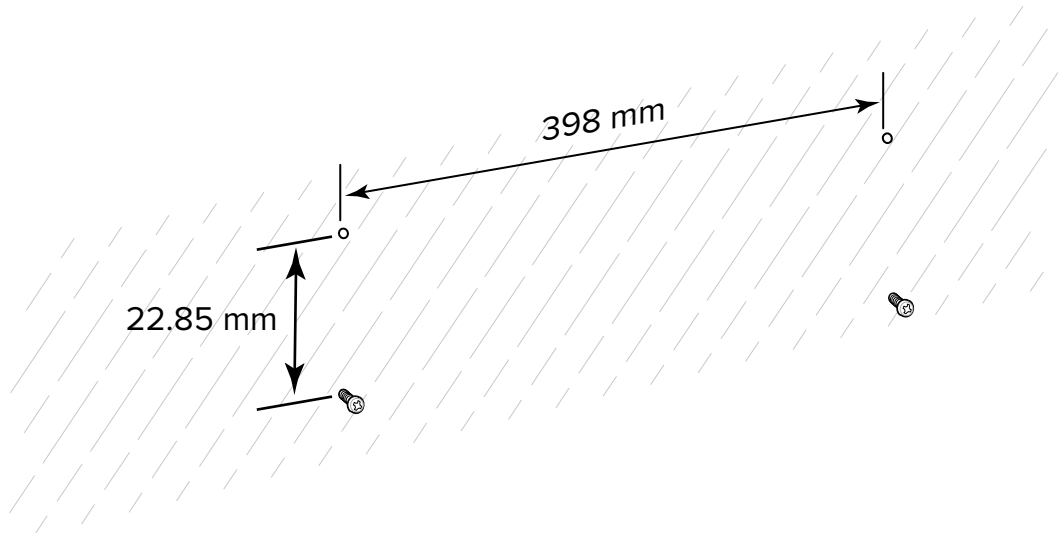

3. Align the mounting bracket's bottom mounting key holes with the screws.
4. Hang the bracket on the screws.

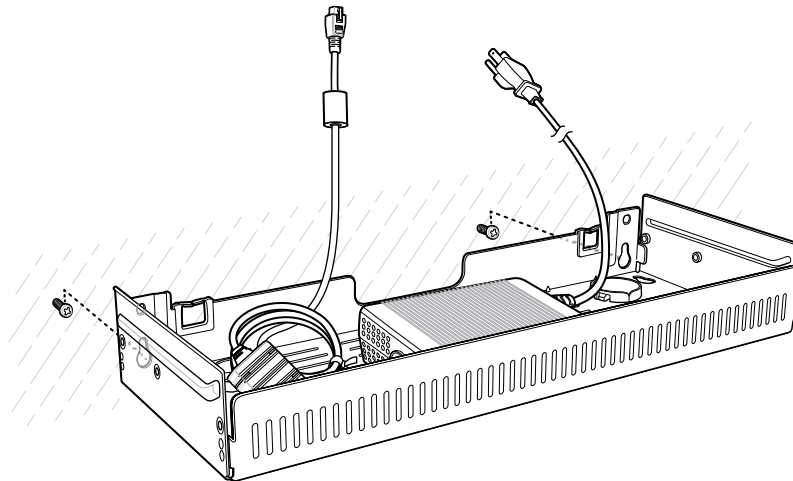

5. Install two top screws.

6. Tighten all screws.

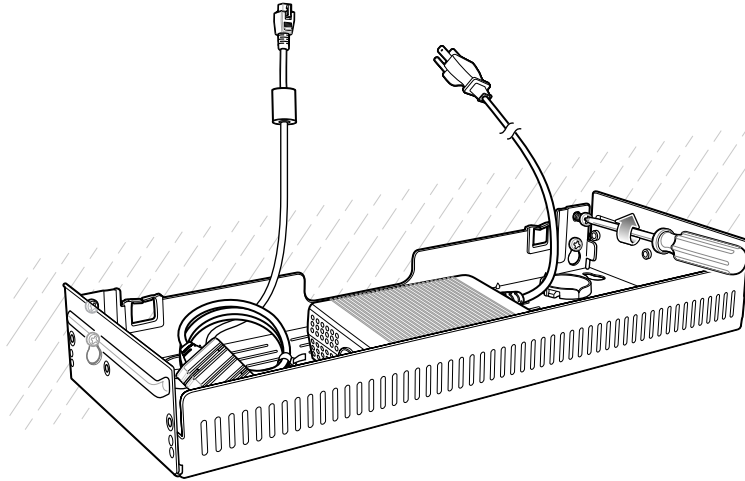

7. Assemble the top tray. See steps 6 through 8 in [Installing 4-Slot Battery Chargers Rack](#) on page 147.

8. Route cables and connect to power source.



**NOTE:** Installer should ensure that all building codes are followed when connecting the power supplies to an AC power source.

While installing the brackets, power supplies and cables:

- Use tie wraps to secure cables to the bracket and rails.
- Coil cables wherever possible.
- Route power cables along the rails.
- Route inter-cradle cables to the side rails and then from the rails to the bracket.

## Condensation Resistant Rear Bezel Replacement

The Condensation Resistant configurations contain a desiccant pack that must be replaced every five months. The desiccant pack is part of the Back Bezel. Replacement Back Bezel with desiccant pack comes in a vacuum sealed package. Do not open the package until instructed in the steps below. Install immediately after opening.

To replace the Back Bezel:

1. Remove six screws securing the Back Bezel.

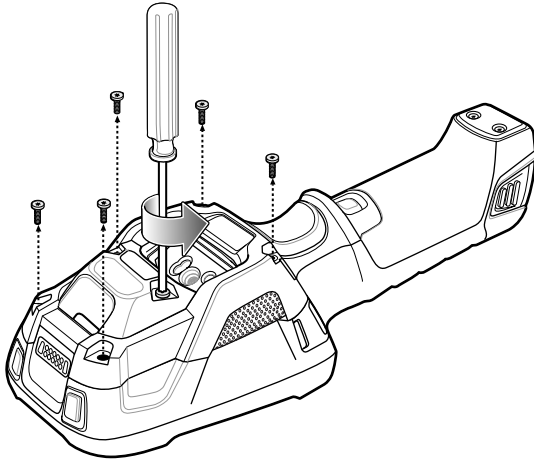

2. Lift Rear Bezel.

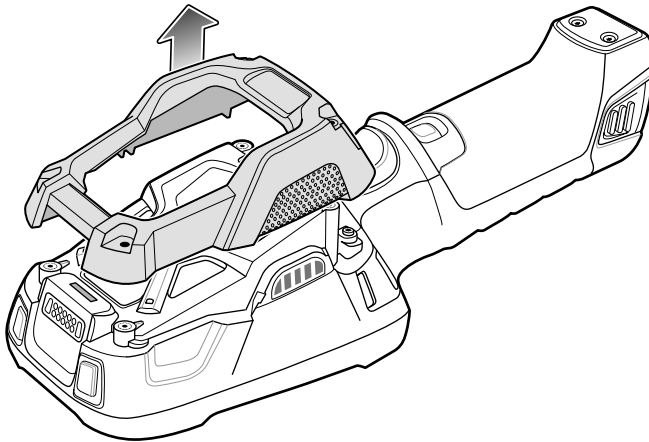

3. Cut the package open with scissors.

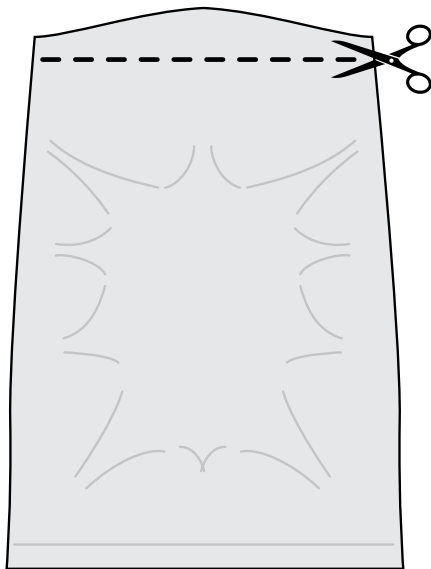

4. Remove Rear Bezel from package.

5. Align Rear Bezel with device.

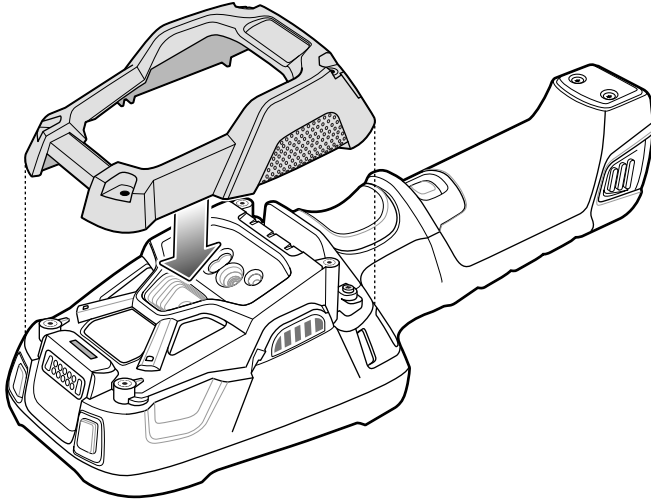

6. Secure Rear Bezel using six screws with a torque requirement of  $4.5 \pm 0.2$  kgf.cm.

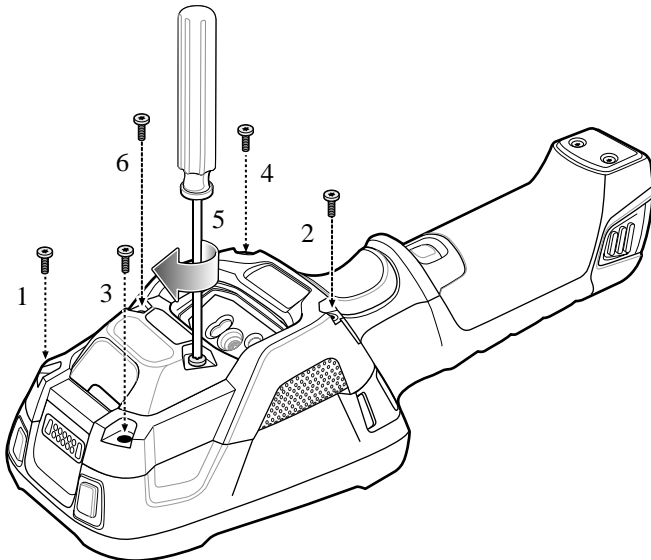

# Application Deployment

This section provides an overview of device security, app development, and app management. It also provides instructions for installing apps and updating the device software.

## Android Security

The device implements a set of security policies that determine whether an application is allowed to run and, if allowed, with what level of trust. To develop an application, you must know the security configuration of the device, and how to sign an application with the appropriate certificate to allow the application to run (and to run with the needed level of trust).



**NOTE:** Ensure the date is set correctly before installing certificates or when accessing secure web sites.

## Installing a Secure Certificate

If required by the VPN or Wi-Fi network, install a secure certificate on the device.

1. Copy the certificate from the host computer to the root of the microSD card or the device's internal memory. See [USB Communication](#) on page 45 for information about connecting the device to a host computer and copying files.
2. Go to **Settings**.
3. Touch **Security > Encryption & credentials**.
4. Touch **Install a certificate** and select one of the following:
  - **CA certificate**
  - **VPN & app user certification**
  - **Wi-Fi certificate**.
5. Navigate to the location of the certificate file.
6. Touch the filename of the certificate to install.
7. If prompted, enter the password for credential storage. If a password has not been set for the credential storage, enter a password for it twice, and then touch **OK**.
8. If prompted, enter the certificate's password and touch **OK**.

The certificate can now be used when connecting to a secure network. For security, the certificate is deleted from the microSD card or internal memory.



## Configuring Credential Storage Settings

Configure credential storage from the device settings.

1. Go to **Settings**.
2. Touch **Security > Encryption & credentials**.
3. Select an option.
  - Touch **Trusted credentials** to display the trusted system and user credentials.
  - Touch **User credentials** to display user credentials.
  - Touch **Install a certificate** to install a secure certificate from the internal storage.
  - Touch **Clear credentials** to delete all secure certificates and related credentials.

## Android Development Tools

Development tools for Android include Android Studio, EMDK for Android, and StageNow.

### Android Development Workstation

Android development tools are available at [developer.android.com](http://developer.android.com).

To start developing applications for the device, download Android Studio. Development can take place on a Microsoft® Windows®, Mac® OS X®, or Linux® operating system.

Applications are written in Java or Kotlin, but compiled and executed in the Dalvik virtual machine. Once the Java code is compiled cleanly, the developer tools make sure the application is packaged properly, including the AndroidManifest.xml file.

Android Studio contains a full featured IDE as well as SDK components required to develop Android applications.

### Enabling Developer Options

The **Developer options** screen sets development-related settings. By default, the Developer Options are hidden.

1. Go to **Settings**.
2. Touch **About phone**.
3. Scroll down to **Build number**.
4. Tap **Build number** seven times.

The message **You are now a developer!** appears.
5. Touch **Back**.
6. Touch **System > Advanced > Developer options**.
7. Slide the **USB debugging** switch to the **ON** position.

### EMDK for Android

EMDK for Android provides developers with tools to create business applications for enterprise mobile devices. It is designed for use with Google's Android Studio and includes Android class libraries such as Barcode, sample applications with source code, and the associated documentation.

EMDK for Android allows applications to take full advantage of the capabilities that Zebra devices have to offer. It embeds Profile Manager technology within Android Studio IDE, providing a GUI-based development tool designed specifically for Zebra devices. This allows fewer lines of code, resulting in reduced development time, effort, and errors.

#### See Also

[For more information go to techdocs.zebra.com.](https://techdocs.zebra.com)

### StageNow for Android

StageNow is Zebra's next-generation Android Staging Solution built on the MX platform. It allows quick and easy creation of device profiles, and can deploy to devices simply by scanning a barcode, reading a tag, or playing an audio file.

The StageNow Staging Solution includes the following components:

- The StageNow Workstation tool installs on the staging workstation (host computer) and lets the administrator easily create staging profiles for configuring device components, and perform other staging actions such as checking the condition of a target device to determine suitability for software upgrades or other activities. The StageNow Workstation stores profiles and other created content for later use.
- The StageNow Client resides on the device and provides a user interface for the staging operator to initiate staging. The operator uses one or more of the desired staging methods (print and scan a barcode, read an NFC tag or play an audio file) to deliver staging material to the device.

#### See Also

[For more information go to techdocs.zebra.com.](https://techdocs.zebra.com)

### GMS Restricted

GMS Restricted mode deactivates Google Mobile Services (GMS). All GMS apps are disabled on the device and communication with Google (analytics data collection and location services) is disabled.

Use StageNow to disable or enable GMS Restricted mode. After a device is in GMS Restricted mode, enable and disable individual GMS apps and services using StageNow. To ensure GMS Restricted mode persists after an Enterprise Reset, use the Persist Manager option in StageNow.

#### See Also

[For more information on StageNow, refer to techdocs.zebra.com.](https://techdocs.zebra.com)

## ADB USB Setup

To use the ADB, install the development SDK on the host computer then install the ADB and USB drivers.

Before installing the USB driver, make sure that the development SDK is installed on the host computer. Go to [developer.android.com/sdk/index.html](http://developer.android.com/sdk/index.html) for details on setting up the development SDK.

The ADB and USB drivers for Windows and Linux are available on the Zebra Support Central web site at [zebra.com/support](http://zebra.com/support). Download the ADB and USB Driver Setup package. Follow the instructions with the package to install the ADB and USB drivers for Windows and Linux.

### Enabling USB Debugging

By default, USB debugging is disabled.

1. Go to **Settings**.
2. Touch **About phone**.
3. Scroll down to **Build number**.
4. Tap **Build number** seven times.  
The message **You are now a developer!** appears.
5. Touch **Back**.
6. Touch **System > Advanced > Developer options**.
7. Slide the **USB debugging** switch to the **ON** position.
8. Touch **OK**.
9. Connect the device to the host computer using the Rugged Charge/USB Cable.

The **Allow USB debugging?** dialog box appears on the device.

If the device and host computer are connected for the first time, the **Allow USB debugging?** dialog box with the **Always allow from this computer** check box displays. Select the check box, if required.

10. Touch **OK** or **Allow**.
11. On the host computer, navigate to the **platform-tools** folder and open a command prompt window.
12. Type `adb devices`.

The following displays:

```
List of devices attached          XXXXXXXXXXXXXXXXXXXX device
```

Where XXXXXXXXXXXXXXXXXXXX is the device number.



**NOTE:** If device number does not appear, ensure that ADB drivers are installed properly.

13. Return to the Home screen.

## Entering Android Recovery Manually

Many of the update methods discussed in this section require putting the device into Android Recovery mode. If you are unable to enter Android Recovery mode through adb commands, use the following steps to manually enter Android Recovery mode.

1. Press and hold the Power button until the menu appears.
2. Touch **Restart**.
3. Press and hold the Scan button until the device vibrates.

The System Recovery screen appears.

## Application Installation Methods

After an application is developed, install the application onto the device using one of the supported methods.

- USB connection
- Android Debug Bridge
- Wireless Android Debug Bridge
- microSD Card
- Mobile device management (MDM) platforms that have application provisioning. Refer to the MDM software documentation for details.

## Installing Applications Using the USB Connection

Use the USB connection to install applications onto the device.

1. Connect the device to a host computer using the Rugged Charge/USB cable.
2. On the device, pull down the Notification panel and touch **Charging this device via USB**.  
By default, **No data transfer** is selected.
3. Touch **File Transfer**.
4. On the host computer, open a file explorer application.
5. On the host computer, copy the application APK file from the host computer to the device.
6. Disconnect the device from the host computer.
7. Swipe the screen up and select  to view files on the microSD card or Internal Storage.
8. Locate the application APK file.
9. Touch the application file.
10. Touch **Continue** to install the app or **Cancel** to stop the installation.
11. To confirm installation and accept what the application affects, touch **Install** otherwise touch **Cancel**.
12. Touch **Open** to open the application or **Done** to exit the installation process.

The application appears in the App list.

## Installing Applications Using the Android Debug Bridge

Use ADB commands to install applications onto the device.

1. Ensure that the ADB drivers are installed on the host computer.
2. Connect the device to a host computer using a USB cable.
3. Go to **Settings**.
4. Touch **System > Advanced > Developer options** .
5. Slide the **USB debugging** switch to the **ON** position.
6. Touch **OK**.
7. If the device and host computer are connected for the first time, the **Allow USB debugging?** dialog box with the **Always allow from this computer** check box displays. Select the check box, if required.
8. Touch **OK** or **Allow**.
9. On the host computer, navigate to the **platform-tools** folder and open a command prompt window.
10. Type `adb install <application>`.  
where: <application> = the path and filename of the apk file.
11. Disconnect the device from the host computer.

## Installing Applications Using Wireless ADB

Use ADB commands to install an application onto the device.

Go to the Zebra Support & Downloads web site at [zebra.com/support](http://zebra.com/support) and download the appropriate Factory Reset file to a host computer.



**IMPORTANT:** Ensure the latest adb files are installed on the host computer.



**IMPORTANT:** The device and host computer must be on the same wireless network.

1. Go to **Settings**.
2. Touch **System > Advanced > Developer options** .
3. Slide the **USB debugging** switch to the **ON** position.
4. Slide the **Wireless debugging** switch to the **ON** position.
5. If the device and host computer are connected for the first time, the **Allow wireless debugging on this network?** dialog box with the **Always allow from this network** check box displays. Select the check box, if required.
6. Touch **ALLOW**.
7. Touch **Wireless debugging**.

8. Touch **Pair with pairing code**.

The **Pair with device** dialog box displays.

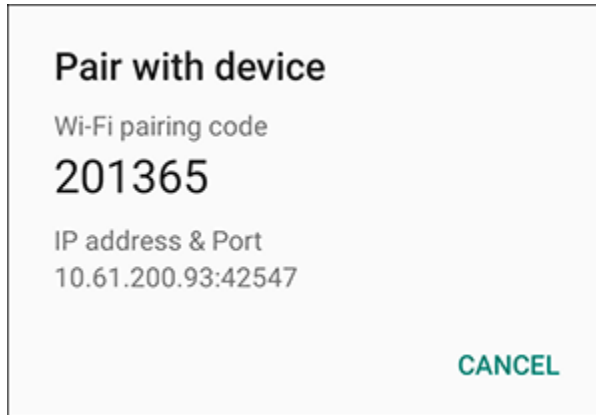

9. On the host computer, navigate to the **platform-tools** folder and open a command prompt window.
10. Type `adb pair XX.XX.XX.XX.XXXXXX`.  
where `XX.XX.XX.XX:XXXXXX` is the IP address and port number from the **Pair with device** dialog box.
11. Press Enter.
12. Type the pairing code from the **Pair with device** dialog box
13. Press Enter.
14. Type `adb connect XX.XX.XX.XX:XXXXXX`.  
where `XX.XX.XX.XX:XXXXXX` is the **IP address & Port** on the **Wireless debugging** screen.  
The device is now connected to the host computer.
15. Type `adb devices`.  
The following displays:

```
List of devices attached      XXXXXXXXXXXXXXXXXXXX device
```

Where XXXXXXXXXXXXXXXXXXXX is the device number.



**NOTE:** If device number does not appear, ensure that ADB drivers are installed properly.

16. On the host computer command prompt window type:

```
adb install <application>
```

where: `<file>` = the path and filename of the apk file.

17. On the host computer, type:



```
adb disconnect.
```

## Installing Applications Using a microSD Card

Use a microSD card to install applications on your device.



**CAUTION:** When connecting the device to a host computer and mounting the microSD card, follow the host computer's instructions for connecting and disconnecting USB devices, to avoid damaging or corrupting files.

1. Copy the APK file to the root of the microSD card.
  - Copy the APK file to a microSD card using a host computer (see [USB Communication](#) on page 45 for more information), and then install the microSD card into the device (see [Installing the microSD Card](#) on page 25 for more information).
  - Connect the device with a microSD card already installed to the host computer, and copy the .apk file to the microSD card. See [USB Communication](#) on page 45 for more information. Disconnect the device from the host computer.
2. Swipe the screen up and select  to view files on the microSD card.
3. Touch  **SD card**.
4. Locate the application APK file.
5. Touch the application file.
6. Touch **Continue** to install the app or **Cancel** to stop the installation.
7. To confirm installation and accept what the application affects, touch **Install** otherwise touch **Cancel**.
8. Touch **Open** to open the application or **Done** to exit the installation process.

The application appears in the App list.

## Uninstalling an Application

Free up device memory by removing unused apps.

1. Go to **Settings**.
2. Touch **Apps & notifications**.
3. Touch **See all apps** to view all apps in the list.
4. Scroll through the list to the app.
5. Touch the app. The **App info** screen appears.
6. Touch **Uninstall**.
7. Touch **OK** to confirm.

## Android System Update

System Update packages can contain either partial or complete updates for the operating system. Zebra distributes the System Update packages on the Zebra Support & Downloads website. Perform a system update using either a microSD card or using ADB.

### Performing a System Update Using microSD Card

It is strongly recommended that prior to use, you must format the microSD card on the device.

Go to the Zebra Support & Downloads web site at [zebra.com/support](http://zebra.com/support) and download the appropriate System Update package to a host computer.

1. Copy the System Update zip file to the root of the microSD card.
  - Copy the ZIP file to a microSD card using a host computer, and then install the microSD card into the device. See Getting Started for information on installing the microSD card.
  - Connect the device with a microSD card already installed to the host computer, copy the ZIP file to the microSD card, and then disconnect the device from the host computer.
2. Press and hold **Power** until the menu appears.
3. Touch **Restart**.
4. Press and hold **Scan** until the device vibrates.

The System Recovery screen appears.
5. Press **Volume Up** and **Volume Down** to navigate to **Apply upgrade from SD card**.
6. Press **Power**.
7. Press **Volume Up** and **Volume Down** to navigate to the System Update file.
8. Press **Power**. The System Update installs and then the device returns to the Recovery screen.
9. Press **Power** to reboot the device.

### Performing a System Update Using ADB

Use ADB to perform a system update.

Go to the Zebra Support & Downloads web site at [zebra.com/support](http://zebra.com/support) and download the appropriate System Update package to a host computer.

1. Connect the device to a host computer using a USB cable.
2. Go to **Settings**.
3. Touch **System > Advanced > Developer options**.
4. Slide the **USB debugging** switch to the **ON** position.
5. Touch **OK**.
6. If the device and host computer are connected for the first time, the **Allow USB debugging?** dialog box with the **Always allow from this computer** check box displays. Select the check box, if required.
7. Touch **OK** or **Allow**.
8. On the host computer, navigate to the **platform-tools** folder and open a command prompt window.



9. Type `adb devices`.

The following displays:

```
List of devices attached          XXXXXXXXXXXXXXXXXXXX device
```

Where XXXXXXXXXXXXXXXXXXXX is the device number.



**NOTE:** If device number does not appear, ensure that ADB drivers are installed properly.

10. Type:

```
adb reboot recovery
```

11. Press **Enter**.

The System Recovery screen appears on the device.

12. Press **Volume Up** and **Volume Down** to navigate to **Apply upgrade from ADB**.

13. Press **Power**.

14. On the host computer command prompt window type:

```
adb sideload <file>
```

where: <file> = the path and filename of the zip file.

15. Press **Enter**.

The System Update installs (progress appears as percentage in the Command Prompt window) and then the System Recovery screen appears on the device.

16. Press **Power** to reboot the device.

17. Disconnect the USB cable from the device.

If you are not able to enter Android Recovery mode through the adb command, see [Entering Android Recovery Manually](#) on page 164.

## Performing a System Update Using Wireless ADB

Use wireless ADB to perform a system update.

Go to the Zebra Support & Downloads web site at [zebra.com/support](http://zebra.com/support) and download the appropriate System Update package to a host computer.



**IMPORTANT:** Ensure the latest adb files are installed on the host computer.



**IMPORTANT:** The device and the host computer must be on the same wireless network.

1. Go to **Settings**.
2. Touch **System > Advanced > Developer options**.
3. Slide the **USB debugging** switch to the **ON** position.
4. Slide the **Wireless debugging** switch to the **ON** position.

5. If the device and host computer are connected for the first time, the **Allow wireless debugging on this network?** dialog box with the **Always allow from this network** check box displays. Select the check box, if required.
6. Touch **ALLOW**.
7. Touch **Wireless debugging**.
8. Touch **Pair with pairing code**.

The **Pair with device** dialog box displays.

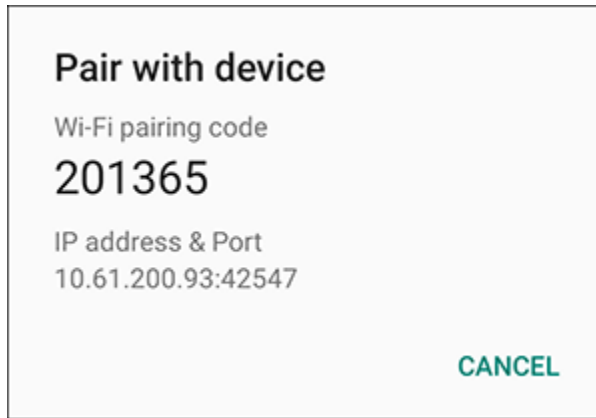

9. On the host computer, navigate to the **platform-tools** folder and open a command prompt window.
10. Type `adb pair XX.XX.XX.XX.XXXXX`  
where `XX.XX.XX.XX.XXXXX` is the IP address and port number from the **Pair with device** dialog box.
11. Press Enter.
12. Type the pairing code from the **Pair with device** dialog box.
13. Press Enter.
14. Type `adb connect XX.XX.XX.XX:XXXXX`  
where `XX.XX.XX.XX:XXXXX` is the **IP address & Port** on the **Wireless debugging** screen.
15. Type `adb devices`.  
The following displays:

```
List of devices attached      XXXXXXXXXXXXXXXXXXXX device
```

Where XXXXXXXXXXXXXXXXXXXX is the device number.



**NOTE:** If device number does not appear, ensure that ADB drivers are installed properly.

16. Type:  
`adb reboot recovery`
17. Press Enter.  
The System Recovery screen appears on the device.
18. Press the Volume Up and Volume Down buttons to navigate to **Apply upgrade from ADB**.

19. Press the Power button.
20. On the host computer command prompt window type:

```
adb sideload <file>
```

where: <file> = the path and filename of the zip file.

21. Press Enter.  
The System Update installs (progress appears as percentage in the Command Prompt window) and then the System Recovery screen appears on the device.
22. Press the Power button to reboot the device.
23. On the host computer, type:  
`adb disconnect.`

If you are not able to enter Android Recovery mode through the adb command, see [Entering Android Recovery Manually](#) on page 164.

### Verifying System Update Installation

Verify that the system update was successful.

1. Go to **Settings**.
2. Touch **About phone**.
3. Scroll down to **Build number**.
4. Ensure that the build number matches the new system update package file number.

### Android Enterprise Reset

An Enterprise Reset erases all user data in the /data partition, including data in the primary storage locations (/sdcard and emulated storage). Zebra distributes the Enterprise Reset packages on the Zebra Support & Downloads website.

Before performing an Enterprise Reset, provision all necessary configuration files and restore after the reset.

Perform Enterprise Reset from the device settings, using a microSD card, or using ADB.

### Performing an Enterprise Reset From Device Settings

Perform an Enterprise Reset from the device settings.

1. Go to **Settings**.
2. Touch **System > Advanced > Reset options > Erase all data (enterprise reset)**.
3. Touch **Erase all data** twice to confirm the Enterprise Reset.

## Performing an Enterprise Reset Using microSD Card

It is strongly recommended that prior to use, you must format the microSD card on the device.

Go to the Zebra Support & Downloads web site at [zebra.com/support](https://zebra.com/support) and download the appropriate Enterprise Reset file to a host computer.

1. Copy the Enterprise Reset zip file to the root of the microSD card.
  - Copy the zip file to a microSD card using a host computer and then install the microSD card into the device. See Getting Started for more information.
  - Connect the device with a microSD card already installed to the host computer and copy zip file to the microSD card. See USB Communication for more information. Disconnect the device from the host computer.
2. Press and hold **Power** until the menu appears.
3. Touch **Restart**.
4. Press and hold **Scan** until the device vibrates.

The System Recovery screen appears.
5. Press **Volume Up** and **Volume Down** to navigate to **Apply upgrade from SD card**.
6. Press **Power**.
7. Press **Volume Up** and **Volume Down** to navigate to the Enterprise Reset file.
8. Press **Power**.

The Enterprise Reset occurs and then the device returns to the Recovery screen.
9. Press **Power** to reboot the device.

## Performing an Enterprise Reset Using ADB

Perform an Enterprise Reset Using ADB.

Go to the Zebra Support & Downloads web site at [zebra.com/support](https://zebra.com/support) and download the appropriate Enterprise Reset file to a host computer.

1. Connect the device to a host computer using a USB cable.
2. Go to **Settings**.
3. Touch **System > Advanced > Developer options**.
4. Slide the **USB debugging** switch to the **ON** position.
5. Touch **OK**.
6. If the device and host computer are connected for the first time, the **Allow USB debugging?** dialog box with the **Always allow from this computer** check box displays. Select the check box, if required.
7. Touch **OK** or **Allow**.
8. On the host computer, navigate to the **platform-tools** folder and open a command prompt window.

9. Type `adb devices`.

The following displays:

```
List of devices attached          XXXXXXXXXXXXXXXXXXXX device
```

Where XXXXXXXXXXXXXXXXXXXX is the device number.



**NOTE:** If device number does not appear, ensure that ADB drivers are installed properly.

10. Type:

```
adb reboot recovery
```

11. Press **Enter**.

The System Recovery screen appears on the device.

12. Press **Volume Up** and **Volume Down** to navigate to **Apply upgrade from ADB**.

13. Press **Power**.

14. On the host computer command prompt window type:

```
adb sideload <file>
```

where: <file> = the path and filename of the zip file.

15. Press **Enter**.

The Enterprise Reset package installs and then the System Recovery screen appears on the device.

16. Press **Power** to reboot the device.

17. Disconnect the USB cable from the device.

If you are not able to enter Android Recovery mode through the adb command, see [Entering Android Recovery Manually](#) on page 164.

## Performing an Enterprise Reset Using Wireless ADB

Perform an Enterprise Reset using Wireless ADB.

Go to the Zebra Support & Downloads web site at [zebra.com/support](http://zebra.com/support) and download the appropriate Factory Reset file to a host computer.



**IMPORTANT:** Ensure the latest adb files are installed on the host computer.



**IMPORTANT:** The device and host computer must be on the same wireless network.

1. Go to **Settings**.

2. On the host computer command prompt window type:

```
adb sideload <file>
```

where: <file> = the path and filename of the zip file.

3. Slide the **USB debugging** switch to the **ON** position.
4. Slide the **Wireless debugging** switch to the **ON** position.
5. If the device and host computer are connected for the first time, the **Allow wireless debugging on this network?** dialog box with the **Always allow from this network** check box displays. Select the check box, if required.
6. Touch **ALLOW**.
7. Touch **Wireless debugging**.
8. Touch **Pair with pairing code**.

The **Pair with device dialog** box displays.

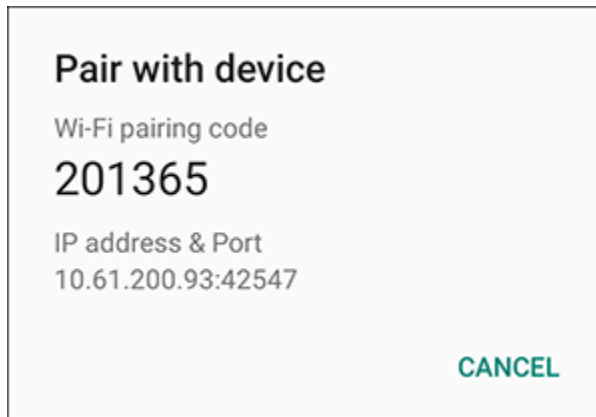

9. On the host computer, navigate to the **platform-tools** folder and open a command prompt window.
10. Type `adb pair XX.XX.XX.XX.XXXXX`.  
where `XX.XX.XX.XX.XXXXX` is the IP address and port number from the **Pair with device** dialog box.
11. Press Enter.
12. Type the pairing code from the **Pair with device** dialog box
13. Press Enter.
14. Type `adb connect XX.XX.XX.XX:XXXXX`.  
where `XX.XX.XX.XX:XXXX` is the **IP address & Port** on the **Wireless debugging** screen.  
The device is now connected to the host computer.
15. Type `adb devices`.  
The following displays:

```
List of devices attached      XXXXXXXXXXXXXXXXXXXX device
```

Where XXXXXXXXXXXXXXXXXXXX is the device number.



**NOTE:** If device number does not appear, ensure that ADB drivers are installed properly.

16. Press Enter.  
The Enterprise Reset package installs and then the System Recovery screen appears on the device.

17. Press the Power button to reboot the device.
18. Press Enter.
19. On the host computer command prompt window type:

```
adb sideload <file>
```

where: <file> = the path and filename of the zip file.

20. Press Enter.  
The Enterprise Reset package installs and then the System Recovery screen appears on the device.
21. Press the Power button to reboot the device.
22. On the host computer, type:  
`adb disconnect.`

If you are not able to enter Android Recovery mode through the adb command, see [Entering Android Recovery Manually](#) on page 164.

## Android Factory Reset

A Factory Reset erases all data in the /data and /enterprise partitions in internal storage and clears all device settings. A Factory Reset returns the device to the last installed operating system image. To revert to a previous operating system version, re-install that operating system image. Zebra distributes the Factory Reset packages on the Zebra Support & Downloads website.

### Performing a Factory Reset Using microSD Card

Perform a Factory Reset using a microSD card.

Go to the Zebra Support & Downloads web site at [zebra.com/support](http://zebra.com/support) and download the appropriate Factory Reset file to a host computer.

1. Copy the Factory Reset zip file to the root of the microSD card.
  - Copy the zip file to a microSD card using a host computer and then installing the microSD card into the device. See Getting Started for more information.
  - Connect the device with a microSD card already installed to the host computer, copy zip file to the microSD card, and then disconnect the device from the host computer.
2. Press and hold **Power** until the menu appears.
3. Touch **Restart**.
4. Press and hold **Scan** until the device vibrates.  
The System Recovery screen appears.
5. Press **Volume Up** and **Volume Down** to navigate to **Apply upgrade from SD card** or **Apply downgrade from SD card**.
6. Press **Power**.
7. Press **Volume Up** and **Down Arrow** to navigate to the Factory Reset file.

8. Press **Power**.

The Factory Reset occurs and then the device returns to the Recovery screen.

9. Press **Power** to reboot the device.

## Performing a Factory Reset Using ADB

Perform a Factory Reset using ADB.

Go to the Zebra Support & Downloads web site at [zebra.com/support](https://zebra.com/support) and download the appropriate Factory Reset file to a host computer.

1. Connect the device to a host computer using a USB cable.
2. Go to **Settings**.
3. Touch **System > Advanced > Developer options**.
4. Slide the **USB debugging** switch to the **ON** position.
5. Touch **OK**.
6. If the device and host computer are connected for the first time, the **Allow USB debugging?** dialog box with the **Always allow from this computer** check box displays. Select the check box, if required.
7. Touch **OK** or **ALLOW**.
8. On the host computer, navigate to the **platform-tools** folder and open a command prompt window.
9. Type `adb devices`.

The following displays:

```
List of devices attached          XXXXXXXXXXXXXXXXXXXX device
```

Where XXXXXXXXXXXXXXXXXXXX is the device number.



**NOTE:** If device number does not appear, ensure that ADB drivers are installed properly.

10. Type:
 

```
adb reboot recovery
```
11. Press **Enter**.
 

The System Recovery screen appears on the device.
12. Press **Volume Up** and **Volume Down** to navigate to **Apply upgrade from ADB** or **Apply downgrade from ADB**.
13. Press **Power**.
14. On the host computer command prompt window type:

```
adb sideload <file>
```

where: <file> = the path and filename of the zip file.

15. Press **Enter**.
 

The Factory Reset package installs and then the System Recovery screen appears on the device.



16. Press **Power** to reboot the device.
17. Disconnect the USB cable from the device.

If you are not able to enter Android Recovery mode through the adb command, see [Entering Android Recovery Manually](#) on page 164.

## Performing a Factory Rest Using Wireless ADB

Perform a Factory Reset using Wireless ADB.

Go to the Zebra Support & Downloads web site at [zebra.com/support](http://zebra.com/support) and download the appropriate Factory Reset file to a host computer.



**IMPORTANT:** Ensure the latest adb files are installed on the host computer.



**IMPORTANT:** The device and host computer must be on the same wireless network.

1. Go to **Settings**.
2. Touch **System > Advanced > Developer options**.
3. Slide the **USB debugging** switch to the **ON** position.
4. Slide the **Wireless debugging** switch to the **ON** position.
5. If the device and host computer are connected for the first time, the **Allow wireless debugging on this network?** dialog box with the **Always allow from this network** check box displays. Select the check box, if required.
6. Touch **ALLOW**.
7. Touch **Wireless debugging**.
8. Touch **Pair with pairing code**.

The **Pair with device** dialog box displays.

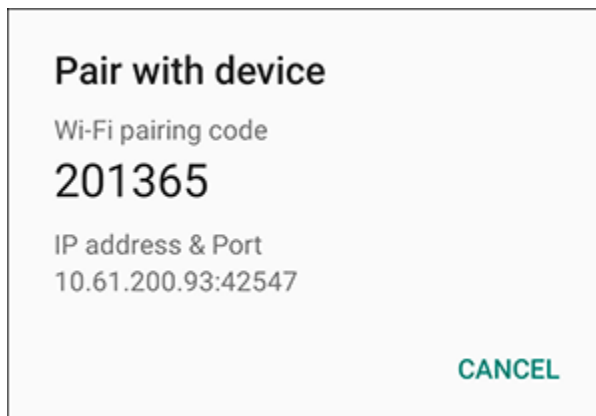

9. On the host computer, navigate to the **platform-tools** folder and open a command prompt window.
10. Type `adb pair XX.XX.XX.XX.XXXXXX`,  
where `XX.XX.XX.XX.XXXXXX` is the IP address and port number from the **Pair with device** dialog box.
11. Press Enter.

12. Type the pairing code from the **Pair with device** dialog box
13. Press Enter.
14. Type `adb connect XX.XX.XX.XX:XXXXX`.  
where `XX.XX.XX.XX:XXXX` is the **IP address & Port** on the **Wireless debugging** screen.
15. Type `adb devices`.  
The following displays:

```
List of devices attached      XXXXXXXXXXXXXXXXXXXX device
```

Where XXXXXXXXXXXXXXXXXXXX is the device number.



**NOTE:** If device number does not appear, ensure that ADB drivers are installed properly.

16. Type:  
`adb reboot recovery`
17. Press Enter.  
The Factory Recovery screen appears on the device.
18. Press **Volume Up** and **Volume Down** to navigate to **Apply upgrade from ADB** or **Apply downgrade from ADB**.
19. Press **Power**.
20. On the host computer command prompt window type:

```
adb sideload <file>
```

where: <file> = the path and filename of the zip file.

21. Press Enter.  
The Factory Reset package installs and then the System Recovery screen appears on the device.
22. Press **Power** to reboot the device.
23. On the host computer, type:  
`adb disconnect`.

If you are not able to enter Android Recovery mode through the adb command, see [Entering Android Recovery Manually](#) on page 164.

## Android Storage

The device contains multiple types of file storage.

- Random Access Memory (RAM)
- Internal storage
- Enterprise folder.

## Random Access Memory

Executing programs use RAM to store data. Data stored in RAM is lost upon a reset.

The operating system manages how applications use RAM. It only allows applications and component processes and services to use RAM when required. It may cache recently used processes in RAM, so they restart more quickly when opened again, but it will erase the cache if it needs the RAM for new activities.

The screen displays the amount of used and free RAM.

- **Performance** - Indicates memory performance.
- **Total memory** - Indicates the total amount of RAM available.
- **Average used (%)** - Indicates the average amount of memory (as a percentage) used during the period of time selected (default - 3 hours).
- **Free** - Indicates the total amount of unused RAM.
- **Memory used by apps** - Touch to view RAM usage by individual apps.

### Viewing Memory

View the amount of memory used and free RAM.

1. Go to **Settings**.
2. Touch **System > Advanced > Developer options**.
3. Touch **Memory**.

## Internal Storage

The device has internal storage. The internal storage content can be viewed and files copied to and from when the device is connected to a host computer. Some applications are designed to be stored on the internal storage rather than in internal memory.

### Viewing Internal Storage

View available and used internal storage on the device.

1. Go to **Settings**.
2. Touch **Storage**.

## External Storage

The device can have a removable microSD card. The microSD card content can be viewed and files copied to and from when the device is connected to a host computer.

### Viewing External Storage

Portable storage displays the total amount of space on the installed microSD card and the amount used.

1. Go to **Settings**.
2. Touch **Storage**.  
Touch **SD card** to view the contents of the card.

3. To unmount the microSD card, touch .

## Formatting a microSD Card as Portable Storage

Format a microSD card as portable storage for the device.

1. Touch **SD card**.
2. Touch  > **Storage settings**.
3. Touch **Format**.
4. Touch **ERASE & FORMAT**.
5. Touch **DONE**.

## Formatting a microSD Card as Internal Memory

You can format a microSD card as internal memory to increase the actual amount of the device's internal memory. Once formatted, the microSD card can only be read by this device.

1. Touch **SD card**.
2. Touch  > **Storage settings**.
3. Touch **Format as internal**.
4. Touch **ERASE & FORMAT**.
5. Touch **DONE**.

## Enterprise Folder

The Enterprise folder (within internal flash) is a super-persistent storage that is persistent after a reset and an Enterprise Reset.

The Enterprise folder is erased during a Factory Reset. The Enterprise folder is used for deployment and device-unique data. The Enterprise folder is approximately 128 MB (formatted). Applications can persist data after an Enterprise Reset by saving data to the enterprise/user folder. The folder is ext4 formatted and is only accessible from a host computer using ADB or from an MDM.

## Managing Apps

Apps use two kinds of memory: storage memory and RAM. Apps use storage memory for themselves and any files, settings, and other data they use. They also use RAM when they are running.

1. Go to **Settings**.
2. Touch **Apps & notifications**.
3. Touch **See all XX apps** to view all apps on the device.
4. Touch  > **Show system** to include system processes in the list.
5. Touch an app, process, or service in the list to open a screen with details about it and, depending on the item, to change its settings, permissions, notifications and to force stop or uninstall it.



## App Details

Apps have different kinds of information and controls.

- **Force stop** - Stop an app.
- **Disable** - Disable an app.
- **Uninstall** - Remove the app and all of its data and settings from the device.
- **Notifications** - Set the app notification settings.
- **Permissions** - Lists the areas on the device that the app has access to.
- **Storage & cache** - Lists how much information is stored and includes buttons for clearing it.
- **Mobile data & Wi-Fi** - Provides information about data consumed by an app.
- **Mobile data & Wi-Fi** - Provides information about data consumed by an app. Mobile data not supported.
- **Advanced**
  - **Screen time** - Displays the amount of time the app has displayed on the screen.
  - **Battery** - Lists the amount of computing power used by the app.
  - **Open by default** - If you have configured an app to launch certain file types by default, you can clear that setting here.
  - **Display over other apps** - Allows an app to display on top of other apps.
  - **App details** - Provides a link to additional app details on the Play store.
  - **Additional settings in the app** - Opens settings in the app.
  - **Modify system settings** - Allows an app to modify the system settings.

## Managing Downloads

Files and apps downloaded using the Browser or Email are stored on the microSD card or Internal storage in the Download directory. Use the Downloads app to view, open, or delete downloaded items.

1. Swipe the screen up and touch .
2. Touch  > **Downloads**.
3. Touch and hold an item, select items to delete and touch . The item is deleted from the device.

# Maintenance and Troubleshooting

This chapter includes instructions on cleaning and storing the device, and provides troubleshooting solutions for potential problems during operation.

## Maintaining the Device

For trouble-free service, observe the following tips when using the device:

- To avoid scratching the screen, use a Zebra approved capacitive compatible stylus intended for use with a touch-sensitive screen. Never use an actual pen or pencil or other sharp object on the surface of the device screen.
- The touch-sensitive screen of the device is glass. Do not drop the device or subject it to strong impact.
- Protect the device from temperature extremes. Do not leave it on the dashboard of a car on a hot day, and keep it away from heat sources.
- Do not store the device in any location that is dusty, damp, or wet.
- Use a soft lens cloth to clean the device. If the surface of the device screen becomes soiled, clean it with a soft cloth moistened with an approved cleanser. For a list of approved cleansers, see [Approved Cleanser Active Ingredients](#) on page 183.
- Periodically replace the rechargeable battery to ensure maximum battery life and product performance. Battery life depends on individual usage patterns.

## Battery Safety Guidelines

- The area in which the units are charged should be clear of debris and combustible materials or chemicals. Particular care should be taken where the device is charged in a non commercial environment.
- Follow battery usage, storage, and charging guidelines found in this guide.
- Improper battery use may result in a fire, explosion, or other hazard.
- To charge the mobile device battery, the ambient battery and charger temperatures must be between +32°F and +104°F (0°C and +40°C) 5°C to 40°C (41°F to 104°F).
- Do not use incompatible batteries and chargers, including non-Zebra batteries and chargers. Use of an incompatible battery or charger may present a risk of fire, explosion, leakage, or other hazard. If you have any questions about the compatibility of a battery or a charger, contact the Global Customer Support Center.

- For devices that utilize a USB port as a charging source, the device shall only be connected to products that bear the USB-IF logo or have completed the USB-IF compliance program.
- Do not disassemble or open, crush, bend or deform, puncture, or shred the battery.
- Severe impact from dropping any battery-operated device on a hard surface could cause the battery to overheat.
- Do not short circuit a battery or allow metallic or conductive objects to contact the battery terminals.
- Do not modify or remanufacture, attempt to insert foreign objects into the battery, immerse or expose to water or other liquids, or expose to fire, explosion, or other hazard.
- Do not leave or store the equipment in or near areas that might get very hot, such as in a parked vehicle or near a radiator or other heat source. Do not place battery into a microwave oven or dryer.
- Battery usage by children should be supervised.
- Please follow local regulations to properly dispose of used rechargeable batteries.
- Do not dispose of batteries in fire.
- In the event of a battery leak, do not allow the liquid to come in contact with the skin or eyes. If contact has been made, wash the affected area with water for 15 minutes, and seek medical advice.
- If you suspect damage to your equipment or battery, contact Customer Support to arrange for inspection.

## Cleaning Instructions



**CAUTION:** Always wear eye protection. Read the warning label on alcohol product before using. If you have to use any other solution for medical reasons please contact the Global Customer Support Center for more information.



**WARNING:** Avoid exposing this product to contact with hot oil or other flammable liquids. If such exposure occurs, unplug the device and clean the product immediately in accordance with these guidelines.

## Approved Cleanser Active Ingredients

100% of the active ingredients in any cleaner must consist of one or some combination of the following: isopropyl alcohol, bleach/sodium hypochlorite<sup>1</sup> (see important note below), or mild dish soap.



**IMPORTANT:** Use pre-moistened wipes and do not allow liquid cleaner to pool.

<sup>1</sup>When using sodium hypochlorite (bleach) based products, always follow the manufacturer's recommended instructions: use gloves during application and remove the residue afterwards with a damp alcohol cloth or a cotton swab to avoid prolonged skin contact while handling the device.

Due to the powerful oxidizing nature of sodium hypochlorite, the metal surfaces on the device are prone to oxidation (corrosion) when exposed to this chemical in the liquid form (including wipes). In the event that these type of disinfectants come in contact with metal on the device, prompt removal with an alcohol-dampened cloth or cotton swab after the cleaning step is critical.

### Harmful Ingredients

The following chemicals are known to damage the plastics on the device and should not come in contact with the device: acetone; ketones; ethers; aromatic and chlorinated hydrocarbons; aqueous or alcoholic alkaline solutions; ethanolamine; toluene; trichloroethylene; benzene; carbolic acid and TB-lysoform.

Many vinyl gloves contain phthalate additives, which are often not recommended for medical use and are known to be harmful to the housing of the device.

### Device Cleaning Instructions

Do not apply liquid directly to the device. Dampen a soft cloth or use pre-moistened wipes. Do not wrap the device in the cloth or wipe, instead gently wipe the unit. Be careful not to let liquid pool around the display window or other places. Before use, allow the unit to air dry.



**NOTE:** For thorough cleaning, it is recommended to first remove all accessory attachments, such as hand straps or cradle cups from the mobile device and to clean them separately.

### Special Cleaning Notes

Do not handle the device while wearing vinyl gloves containing phthalates. Remove vinyl gloves and wash hands to eliminate any residue left from the gloves.

If products containing any of the harmful ingredients listed above are used prior to handling the device, such as a hand sanitizer that contains ethanolamine, hands must be completely dry before handling the device to prevent damage to the device.



**IMPORTANT:** If the battery connectors are exposed to cleaning agents, thoroughly wipe off as much of the chemical as possible and clean with an alcohol wipe. It is also recommended to install the battery in the terminal prior to cleaning and disinfecting the device to help minimize buildup on the connectors. When using cleaning/disinfectant agents on the device, it is important to follow the directions prescribed by the cleaning/disinfectant agent manufacturer.

### Cleaning Materials Required

- Alcohol wipes
- Lens tissue
- Cotton-tipped applicators
- Isopropyl alcohol
- Can of compressed air with a tube.

### Cleaning Frequency

The cleaning frequency is at the customer's discretion due to the varied environments in which the mobile devices are used and may be cleaned as frequently as required. When dirt is visible, it is recommended to clean the mobile device to avoid build up of particles which make the device more difficult to clean later on.



### Cleaning the Device

This section describes how to clean the housing, display, and exit window for the device.

#### Housing

Thoroughly wipe the housing, including all buttons and triggers, using an approved alcohol wipe.

#### Display

The display can be wiped down with an approved alcohol wipe, but care should be taken not to allow any pooling of liquid around the edges of the display. Immediately dry the display with a soft, non-abrasive cloth to prevent streaking.

#### Exit Window

Wipe the exit window periodically with a lens tissue or other material suitable for cleaning optical material such as eyeglasses.

### Cleaning Battery Connectors

1. Remove the main battery from the mobile computer.
2. Dip the cotton portion of the cotton-tipped applicator in isopropyl alcohol.
3. To remove any grease or dirt, rub the cotton portion of the cotton-tipped applicator back and forth across the connectors on the battery and terminal sides. Do not leave any cotton residue on the connectors.
4. Repeat at least three times.
5. Use a dry cotton-tipped applicator and repeat steps 3 and 4. Do not leave any cotton residue on the connectors.
6. Inspect the area for any grease or dirt and repeat the cleaning process if necessary.



**CAUTION:** After cleaning the battery connectors with bleach-based chemicals, follow the Battery Connector Cleaning instructions to remove bleach from the connectors.

### Cleaning Cradle Connectors

1. Remove the DC power cable from the cradle.
2. Dip the cotton portion of the cotton-tipped applicator in isopropyl alcohol.
3. Rub the cotton portion of the cotton-tipped applicator along the pins of the connector. Slowly move the applicator back and forth from one side of the connector to the other. Do not leave any cotton residue on the connector.
4. All sides of the connector should also be rubbed with the cotton-tipped applicator.
5. Remove any lint left by the cotton-tipped applicator.
6. If grease and other dirt can be found on other areas of the cradle, use a lint-free cloth and alcohol to remove.

7. Allow at least 10 to 30 minutes (depending on ambient temperature and humidity) for the alcohol to air dry before applying power to cradle.

If the temperature is low and humidity is high, longer drying time is required. Warm temperature and low humidity requires less drying time.



**CAUTION:** After cleaning the cradle connectors with bleach-based chemicals, follow the Cleaning Cradle Connectors instructions to remove bleach from the connectors.

## Troubleshooting

In rare circumstances, to troubleshoot the device, you may need to reset the device.

### Resetting the Device

This section describes options to reset the device.

There are four reset functions:

- Soft reset
- Hard reset
- Enterprise reset.
- Factory reset.

#### Performing a Soft Reset

Perform a soft reset if applications stop responding.

1. Press and hold **Power** until the menu appears.
2. Touch **Restart**.

The device reboots.

#### Performing a Hard Reset



**CAUTION:** Perform a hard reset only if the TC8300 stops responding.

1. Simultaneously press and hold the power button, trigger and PTT button for five seconds.
2. When the device reboots, release the buttons and trigger.

## Troubleshooting the Device

**Table 25** Troubleshooting the TC8300

Problem	Cause	Solution
Device does not turn on.	Battery not charged.	Charge or replace the battery in the device.
	Battery not installed properly.	Ensure battery is installed properly. See <a href="#">Installing the Battery</a> on page 27.

**Table 25** Troubleshooting the TC8300 (Continued)

Problem	Cause	Solution
	System crash.	Perform a soft reset. If the device still does not turn on, perform a hard reset. See <a href="#">Resetting the Device</a> on page 186.
Battery did not charge.	Battery failed.	Replace battery. If the device still does not operate, try a soft reset, then a hard reset. See <a href="#">Resetting the Device</a> on page 186.
	Device removed from cradle before charging completed.	Insert the device into the cradle and begin charging. The 6,700 mAh battery charges from 0 - 90% in less than four hours at room temperature. The 7,000 mAh battery charges from 0 - 90% in less than five hours at room temperature.
	Ambient temperature of the cradle is too warm or too cold.	The ambient temperature must be between 0 °C and 40 °C (32 °F and 104 °F).
During data communication, no data was transmitted, or transmitted data was incomplete.	Device unplugged from host computer during communication.	Reconnect the programming cable to the host computer and re-transmit.
	Communication software was incorrectly installed or configured.	See system administrator.
Device turns itself off.	Device is inactive	The device turns off after a period of inactivity. If the device is running on battery power, this period can be set to 15 seconds, 30 seconds, 1 minute, 2 minutes, 5 minutes, 10 minutes, or 30 minutes.  Change the setting if you need a longer delay before the automatic shutoff feature activates.
	Battery is depleted.	Place the device in the cradle to re-charge the battery.
	Battery is not inserted properly.	Insert the battery properly (see <a href="#">Installing the Battery</a> on page 27).
	The device's battery is low and it powers down to protect memory content.	Place the device in the cradle to re-charge the battery.
A message appears stating that the device memory is full.	Too many files stored on the device.	Delete unused memos and records. You can save these records on the host computer.
	Too many applications installed on the device.	If you have installed additional applications on the device, remove them to recover memory. See <a href="#">Uninstalling an Application</a> on page 167.
The device does not accept scan input.	Unreadable barcode.	Ensure the symbol is not defaced.
	Distance between scanner exit window and barcode is incorrect.	Move the device closer or further from the barcode to the proper scanning range.

**Table 25** Troubleshooting the TC8300 (Continued)

Problem	Cause	Solution
	Device is not programmed for the barcode.	Verify that the device can read the type of barcode being scanned (See <a href="#">Specifications</a> on page 189). Ensure that the barcode parameters are set properly for the barcode being scanned.
	Device is not programmed to generate a beep.	Verify that a beep on a good decode is used.
During USB data communications, no data was transmitted, or transmitted data was incomplete.	Incorrect cable connection.	See <a href="#">Accessories</a> on page 120.
	Communications software is not installed or configured properly.	See <a href="#">Accessories</a> on page 120.

# Specifications

For device technical specifications, go to [www.zebra.com/support](http://www.zebra.com/support).

## Data Capture Supported Symbologies

**Table 26** Data Capture Options

Item	Description
1D Barcodes	Chinese 2 of 5, Codabar, Code 11, Code 128, Code 39, Code 93, Discrete 2 of 5, EAN-8, EAN-13, GS1 DataBar, GS1 DataBar 14, GS1 DataBar Expanded GS1, GS1 DataBar Limited, Interleaved 2 of 5, Korean 2 of 5, Matrix 2 of 5, MSI, TLC39, Trioptic 39, UPCA, UPCE, UPCE1
2D Barcodes	Australian Postal, Aztec, Canadian Postal, Composite AB, Composite C, Data Matrix, DotCode, Dutch Postal, HAN XIN, Japanese Postal, Mail Mark, Maxi Code, Micro PDF-417, microQR, PDF-417, QR Code, US Planet, UK Postal, US Postnet, USPS 4-state (US4CB), US4state FICS

## SE965 Standard Range Laser Decode Zones

The table below lists the typical distances for selected barcode densities. The minimum element width (or “symbol density”) is the width in mils of the narrowest element (bar or space) in the symbol.

**Table 27** SE965 Decode Distances

Symbol Density/ Barcode Type/ W-N Ratio	Barcode Content/ Contrast (Note 1)	Typical Working Ranges	
		Near	Far
5.0 mil Code 128	1234 80% MRD	1.2 in. 3.05 cm	7.7 in. 19.56 cm
5.0 mil Code 39; 2.5:1	ABCDEFGH 80% MRD	1.2 in. 3.05 cm	12.5 in. 31.75 cm
7.5 mil Code 39; 2.5:1	ABCDEF 80% MRD	1.1 in. 2.79 cm	18.5 in. 46.99 cm
10 mil Code 128	1234 80% MRD	1.2 in. (Note 3) 3.05 cm (Note 3)	19.0 in. 48.26 cm

**Table 27** SE965 Decode Distances (Continued)

Symbol Density/ Barcode Type/ W-N Ratio	Barcode Content/ Contrast (Note 1)	Typical Working Ranges	
		Near	Far
13 mil 100% UPC	12345678905 80% MRD	1.6 in. 4.06 cm	27.0 in. 68.58 cm
15 mil Code 128	1234 80% MRD	1.0 in. (Note 3) 2.54 cm (Note 3)	29.5 in. 74.93 cm
20 mil Code 39; 2.2:1	123 80% MRD	1.4 in. (Note 3) 3.56 cm (Note 3)	52.0 in. 132.08 cm
55 mil Code 39; 2.2:1	CD 80% MRD	3.4 in. (Note 3) 8.64 cm (Note 3)	100.0 in. 254.00 cm
100 mil Code 39; 3.0:1 reflective	123456 80% MRD	2 ft (Note 3) 60.96 cm (Note 3)	17 ft 518.16 cm
Notes: <ul style="list-style-type: none"> <li>• Contrast measured as Mean Reflective Difference (MRD) at 650 nm.</li> <li>• Working range specifications at ambient temperature (23°C), photographic quality symbols. Pitch=10°, roll=0°, skew=0°, ambient light &lt; 150 ft-candles using Symbol or equivalent decoder.</li> <li>• Dependent on width of barcode.</li> <li>• Distances measured from front edge of scan engine chassis.</li> </ul>			

## SE4750-MR Decode Zones

The table below lists the typical distances for selected barcode densities.

**Table 28** SE4750-MR Decode Distances

Symbology	Typical Working Ranges	
	Near	Far
5 mil Code 128	7.4 in. 18.8 cm	16.0 in. 40.6 cm
5 mil PDF417	8.1 in. 20.6 cm	13.1 in. 33.3 cm
7.5 mil Data Matrix	8.3 in. 21.1 cm	12.8 in. 32.5 cm
10 mil Data Matrix	7.0 in. 17.8 cm	17.0 in. 43.2 cm
13 mil UPCA	2.3* in. 5.8* cm	38.0 in. 96.5 cm

**Table 28** SE4750-MR Decode Distances (Continued)

Symbology	Typical Working Ranges	
	Near	Far
15 mil Code 128	4.0* in. 10.2* cm	40.0 in. 101.6 cm
20 mil Code 39	2.1* in. 5.3* cm	54.0 in. 137.2 cm
100 mil Code 39	11.0 in. 27.9 cm	172.0 in. 436.9 cm
160 mil Data Matrix	11.5 in. 29.2 cm	138.0 in. 350.5 cm
<p>* Limited by width of barcode in field of view.                      Note:</p> <ul style="list-style-type: none"> <li>• Photographic quality barcode at 18° tilt pitch angle under 30 fcd ambient illumination.</li> <li>• Distances measured from front edge of scan engine chassis.</li> </ul>		

## SE4750-DP Decode Zones

The table below lists the typical distances for selected barcode densities.

**Table 29** SE4750-DP Decode Distances

Symbology	Typical Working Ranges	
	Near	Far
3 mil Code 39	1.7 in. 4.3 cm	4.3 in. 10.9 cm
5 mil PDF417	1.7 in. 4.3 cm	4.3 in. 10.9 cm
6.67 mil PDF417	1.7* in. 4.3 cm	4.7 in. 11.9 cm
5 mil Data Matrix	1.9 in. 4.8 cm	4.0 in. 10.2 cm
10 mil Data Matrix	1.6 in. 4.1 cm	4.9 in. 12.5 cm
5 mil QR Code	1.9 in. 4.8 cm	4.0 in. 10.2 cm
10 mil QR	1.1 in. 2.6 cm	5.0 in. 12.7 cm

**Table 29** SE4750-DP Decode Distances (Continued)

Symbology	Typical Working Ranges	
	Near	Far
13.0 mil 100% UPC	2.4* in. 6.1* cm	7.3 in. 18.5 cm
* Limited by width of barcode in field of view. Note: <ul style="list-style-type: none"> <li>• Photographic quality barcode 30 fcd ambient illumination.</li> <li>• Distances measured with DPM Mode Off.</li> </ul>		

## SE4750-DPW Decode Zones

The table below lists the typical distances for selected barcode densities.

**Table 30** SE4750-DPW Decode Distances

Symbology	Typical Working Ranges	
	Near	Far
5 mil Code 39	1.4 in. 3.6 cm	7.0 in. 17.8 cm
15 mil Code 128	4.7 in. 11.9 cm	12.5 in. 31.8 cm
5 mil PDF417	1.7 in. 4.3 cm	4.3 in. 10.9 cm
6.67 mil PDF417	1.4 in. 3.6 cm	5.5 in. 14.0 cm
10 mil Data Matrix	1.4 in. 3.6 cm	6.1 in. 15.5 cm
10 mil QR	1.4 in. 3.6 cm	6.1 in. 15.5 cm
13.0 mil 100% UPC	1.8 in. 4.6 cm	12.0 in. 30.5 cm
* Limited by width of barcode in field of view. Note: <ul style="list-style-type: none"> <li>• Photographic quality barcode 30 fcd ambient illumination.</li> <li>• Distances measured with DPM Mode Off.</li> </ul>		



## SE4770-SR Decode Zones

The table below lists the typical distances for selected barcode densities.

**Table 31** SE4770-SR Decode Distances

Symbology	Typical Working Ranges	
	Near	Far
3 mil Code 39	3.0 in. 7.6 cm	5.8 in. 14.7 cm
5 mil Code 128	2.3 in. 5.8 cm	9.8 in. 24.9 cm
5 mil PDF417	3.0 in. 7.6 cm	7.9 in. 20.1 cm
6.67 mil PDF417	2.5 in. 6.4 cm	10.1 in. 25.7 cm
10 mil DataMatrix	2.1 in. 5.3 cm	11.0 in. 27.9 cm
100% UPCA	1.6 in. 4.1 cm	24.9 in. 63.2 cm
15 mil Code 128	2.4 in. 6.1* cm	27.8 in. 70.1 cm
20 mil Code 39	1.6 in. 4.1 cm	36.1 in. 91.7 cm
20 mil QR	1.1 in. 2.8 cm	17.5 in. 44.5 cm
<p>* Limited by width of barcode in field of view.                      Note:</p> <ul style="list-style-type: none"> <li>• Photographic quality barcode at 18° tilt pitch angle under 30 fcd ambient illumination.</li> <li>• Distances measured from front edge of scan engine chassis.</li> </ul>		

## SE4850 Decode Zones

The table below lists the typical distances for selected barcode densities.

**Table 32** SE4850 Decode Distances

Symbology	Typical Working Ranges	
	Near	Far
10 mil Code 39	3.0 in. * 7.6 cm *	85.0 in. 215.9 cm

**Table 32** SE4850 Decode Distances (Continued)

Symbology	Typical Working Ranges	
	Near	Far
13 100% UPC	3.5 in. 8.9 cm	90.0 in. 228.6 cm
15 mil Code 128	6.0 in. * 15.2 cm *	100.0 in. 254.0 cm
20 mil Code 39	4.0 in. * 10.2 cm *	172.0 in. 436.9 cm
40 mil Code 39	6.0 in. * 15.2 cm *	340.0 in. ** 863.6 cm **
55 mil Code 39	7.0* in. * 17.8* cm *	430.0 in. ** 1092.2 cm **
100 mil Code 39 (paper)	20.0* in. * 50.8* cm *	700.0 in. ** 1778.0 cm **
100 mil Code 128 (reflective)	30.0 in. * 76.2 cm *	700.0 in. 1778.0 cm
DataMatrix 10	5.0 in. 12.7 cm	45.0 in. 114.3 cm
DataMatrix 55	5.0 in. 12.7 cm	250.0 in. 635.0 cm
15 mil Code 128 (4 in. wide)	8.0 in. * 20.3 cm *	100.0 in. 254.0 cm
* Limited by width of barcode in field of view. ** Range is reduced under low ambient light level.		

## I/O Connector Pin-Outs

**Figure 43** I/O Connector

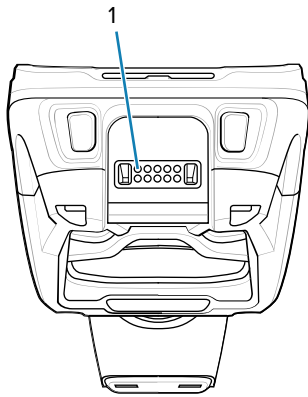

1	Pin 1
---	-------

**Table 33** I/O Connector Pin-Outs

Pin	Signal	Description
1	DGND	Digital ground
2	MUX_RX_HMIC	External headset microphone/RX
3	POWER_IN	Adapter voltage in
4	HST_PLUGDET	Headset or accessory detection
5	DGND	Audio path Ground
6	USB_ID	USB OTG ID pin.
7	MUX_TX_HSL	External headset speaker/TX
8	USB_PWR	USB VBUS Power
9	OTG_DP	USB OTG D+
10	OTG_DM	USB OTG D-

## 2-Slot USB Charge Cradle Technical Specifications

**Table 34** 2-Slot USB Charge Cradle Technical Specifications

Item	Description
Dimensions	Height: 137.5 mm (5.41 in.) Width: 195.6 mm (7.70 in.) Depth: 134.5 mm (5.29 in.)
Weight	838 g (29.6 oz.)
Input Voltage	12 VDC

**Table 34** 2-Slot USB Charge Cradle Technical Specifications (Continued)

Item	Description
Power Consumption	20 watts
Operating Temperature	0 °C to 50 °C (32 °F to 122 °F)
Storage Temperature	-40 °C to 70 °C (-40 °F to 158 °F)
Charging Temperature	0 °C to 40 °C (32 °F to 104 °F)
Humidity	5% to 95% non-condensing
Drop	76.2 cm (30.0 in.) drops to vinyl tiled concrete at room temperature.
Electrostatic Discharge (ESD)	+/- 20kV air +/- 10 kV contact +/- 10 kV indirect discharge

## 2-Slot DPM USB Charge Cradle Technical Specifications

**Table 35** 2-Slot DPM USB Charge Cradle Technical Specifications

Item	Description
Dimensions	Height: 137.5 mm (5.41 in.) Width: 195.6 mm (7.70 in.) Depth: 134.5 mm (5.29 in.)
Weight	838 g (29.6 oz.)
Input Voltage	12 VDC
Power Consumption	20 watts
Operating Temperature	0 °C to 50 °C (32 °F to 122 °F)
Storage Temperature	-40 °C to 70 °C (-40 °F to 158 °F)
Charging Temperature	0 °C to 40 °C (32 °F to 104 °F)
Humidity	5% to 95% non-condensing
Drop	76.2 cm (30.0 in.) drops to vinyl tiled concrete at room temperature.
Electrostatic Discharge (ESD)	+/- 20kV air +/- 10 kV contact +/- 10 kV indirect discharge

## 5-Slot Charge Only Cradle Technical Specifications

**Table 36** 5-Slot Charge Only Cradle Technical Specifications

Item	Description
Dimensions	Height: 108.1 mm (4.26 in.) Width: 489.0 mm (19.25 in.) Depth: 134.5 mm (5.30 in.)
Weight	2.14 kg (4.71 lbs.)
Input Voltage	12 VDC
Power Consumption	60 watts
Operating Temperature	0 °C to 50 °C (32 °F to 122 °F)
Storage Temperature	-40 °C to 70 °C (-40 °F to 158 °F)
Charging Temperature	0 °C to 40 °C (32 °F to 104 °F)
Humidity	5% to 95% non-condensing
Drop	76.2 cm (30.0 in.) drops to vinyl tiled concrete at room temperature.
Electrostatic Discharge (ESD)	+/- 20kV air +/- 10 kV contact +/- 10 kV indirect discharge

## 5-Slot Charge Only Cradle with Battery Charger Technical Specifications

**Table 37** 5-Slot Charge Only Cradle with Battery Charger Technical Specifications

Item	Description
Dimensions	Height: 137.0 mm (5.39 in.) Width: 489.0 mm (19.25 in.) Depth: 134.5 mm (5.30 in.)
Weight	2.33 kg (5.13 lbs.)
Input Voltage	12 VDC
Power Consumption	75 watts
Operating Temperature	0 °C to 50 °C (32 °F to 122 °F)
Storage Temperature	-40 °C to 70 °C (-40 °F to 158 °F)
Charging Temperature	0 °C to 40 °C (32 °F to 104 °F)
Humidity	5% to 95% non-condensing
Drop	76.2 cm (30.0 in.) drops to vinyl tiled concrete at room temperature.

## Specifications

**Table 37** 5-Slot Charge Only Cradle with Battery Charger Technical Specifications (Continued)

Item	Description
Electrostatic Discharge (ESD)	+/- 20kV air +/- 10 kV contact +/- 10 kV indirect discharge

### 5-Slot Ethernet Cradle Technical Specifications

**Table 38** 5-Slot Ethernet Cradle Technical Specifications

Item	Description
Dimensions	Height: 108.1 mm (4.26 in.) Width: 489.0 mm (19.25 in.) Depth: 134.5 mm (5.30 in.)
Weight	2.22 kg (4.89 lbs.)
Input Voltage	12 VDC
Power Consumption	67 watts
Operating Temperature	0 °C to 50 °C (32 °F to 122 °F)
Storage Temperature	-40 °C to 70 °C (-40 °F to 158 °F)
Charging Temperature	0 °C to 40 °C (32 °F to 104 °F)
Humidity	5% to 95% non-condensing
Drop	76.2 cm (30.0 in.) drops to vinyl tiled concrete at room temperature.
Electrostatic Discharge (ESD)	+/- 20kV air +/- 10 kV contact +/- 10 kV indirect discharge

### 5-Slot Ethernet Cradle with Battery Charger Technical Specifications

**Table 39** 5-Slot Ethernet Cradle with Battery Charger Technical Specifications

Item	Description
Dimensions	Height: 137.0 mm (5.39 in.) Width: 489.0 mm (19.25 in.) Depth: 134.5 mm (5.30 in.)
Weight	2.36 kg (5.20 lbs.)
Input Voltage	12 VDC
Power Consumption	82 watts
Operating Temperature	0 °C to 50 °C (32 °F to 122 °F)

## Specifications

**Table 39** 5-Slot Ethernet Cradle with Battery Charger Technical Specifications (Continued)

Item	Description
Storage Temperature	-40 °C to 70 °C (-40 °F to 158 °F)
Charging Temperature	0 °C to 40 °C (32 °F to 104 °F)
Humidity	5% to 95% non-condensing
Drop	76.2 cm (30.0 in.) drops to vinyl tiled concrete at room temperature.
Electrostatic Discharge (ESD)	+/- 20kV air +/- 10 kV contact +/- 10 kV indirect discharge

### 4-Slot Battery Charger Technical Specifications

**Table 40** 4-Slot Battery Charger Technical Specifications

Item	Description
Dimensions	Height: 129.6 mm (5.10 in.) Width: 97.5 mm (3.84 in.) Depth: 134.5 mm (5.30 in.)
Weight	570 g (20.11 oz.)
Input Voltage	12 VDC
Power Consumption	27 watts
Operating Temperature	0 °C to 40 °C (32 °F to 104 °F)
Storage Temperature	-40 °C to 70 °C (-40 °F to 158 °F)
Charging Temperature	0 °C to 40 °C (32 °F to 104 °F)
Humidity	5% to 95% non-condensing
Drop	76.2 cm (30.0 in.) drops to vinyl tiled concrete at room temperature.
Electrostatic Discharge (ESD)	+/- 20kV air +/- 10 kV contact +/- 10 kV indirect discharge

### USB and Charging Cable Technical Specifications

**Table 41** USB and Charging Cable Technical Specifications

Item	Description
Length	150 cm (5.90 in.)
Input Voltage	5.4 VDC (external power supply)
Operating Temperature	-20 °C to 50 °C (-4 °F to 122 °F)

**Table 41** USB and Charging Cable Technical Specifications (Continued)

Item	Description
Storage Temperature	-40 °C to 70 °C (-40 °F to 158 °F)
Humidity	10% to 95% non-condensing
Electrostatic Discharge (ESD)	+/- 20kV air +/- 10 kV contact

## Quick Disconnect Audio Cable Technical Specifications

**Table 42** Quick Disconnect Audio Cable Technical Specifications

Item	Description
Length	40 cm (15.75 in.)
Input Voltage	5.4 VDC
Operating Temperature	-20 °C to 50 °C (-4 °F to 122 °F)
Storage Temperature	-40 °C to 70 °C (-40 °F to 158 °F)
Humidity	10% to 95% non-condensing
Electrostatic Discharge (ESD)	+/- 20kV air +/- 10 kV contact

## 3.5 mm Audio Cable Technical Specifications

**Table 43** 3.5 mm Audio Cable Technical Specifications

Item	Description
Length	21.7 cm (8.54 in.)
Input Voltage	5.4 VDC
Operating Temperature	-20 °C to 50 °C (-4 °F to 122 °F)
Storage Temperature	-40 °C to 70 °C (-40 °F to 158 °F)
Humidity	10% to 95% non-condensing
Electrostatic Discharge (ESD)	+/- 20kV air +/- 10 kV contact



